

USE AND MAINTENANCE MANUAL

WIDE-OPENING FORK POSITIONER

ORIGINAL INSTRUCTIONS

INTRODUCTION

This manual contains instructions for assembly, periodic and extraordinary maintenance and troubleshooting.

The instructions in this manual supplement, and do not replace, the obligation to obey occupational safety and accident-prevention laws, which is the user company's responsibility. The user company is, likewise, required to follow all the instructions in this manual, including training its personnel to use and maintain the attachment.

SPECIFICATIONS AND USE OF THE ATTACHMENT

Attachment, to be hooked to forklift trucks, for positioning the forks when handling medium and wide loads. It consists of a guide frame to support the forks, complete with hooks with ISO 2328 profiles for fastening to the truck, without or without side shifting; hydraulic power plant with synchronisation of the jaws by differentiated-diameter linear actuators and closed-circuit valves with automatic zeroing; FEM forks with ISO 2328 profiles hooked to supports driven by opposing actuators.

SYMBOLS USED



Situation with possible risks for the operator's safety.



Procedure that must be performed.



Notes to read carefully.

INDEX

1.	RECOMMENDATIONS FOR USING THE EQUIPMENT	Page 2	5.	HYDRAULIC POWER PLANT	Page 5	10.2.	SLIDE BLOCK DISASSEMBLY AND REPLACEMENT	Page 8
1.1.	PROHIBITED MOVEMENTS	Page 2	5.1.	CONNECTION WITHOUT SHIFTING	Page 5	10.3.	CYLINDER DISASSEMBLY	Page 8
1.2.	CORRECT MOVEMENTS	Page 2	5.1.1.	DIAGRAM WITHOUT CUT-OFF	Page 5	10.4.	REPLACING GASKETS	Page 8
2.	FORKLIFT CHECKS	Page 2	5.1.2.	DIAGRAM WITH CUT-OFF CLOSED	Page 5	10.5.	FASTENING CYLINDERS	Page 9
3.	ATTACHMENT DESCRIPTION	Page 3	5.2.	CONNECTION WITH SHIFTING	Page 5	10.5.1.	ROD SIDE	Page 9
3.1.	SHIPPING CONFIGURATION	Page 3	5.2.1.	DIAGRAM WITHOUT CUT-OFF	Page 5	10.5.2.	BOX SIDE	Page 9
3.2.	FRONT DESCRIPTION	Page 3	5.2.2.	DIAGRAM WITH CUT-OFF CLOSED	Page 5	10.6.	VALVE DISASSEMBLY	Page 9
3.2.1.	REAR DESCRIPTION WITHOUT SHIFTER	Page 3	5.3.	MOVEMENT CHECKS	Page 5	10.7.	SIDE-MOVEMENT MAINTENANCE	Page 9
3.2.2.	REAR DESCRIPTION WITH SHIFTER	Page 3	6.	MOUNTING THE FORKS	Page 6	10.7.1.	UNHOOKING FROM THE TRUCK	Page 9
4.	FIXING TO THE TRUCK	Page 4	6.1.	130-mm FORKS	Page 6	10.7.2.	CYLINDER AND SLIDE BLOCK DISASSEMBLY	Page 9
4.1.	HOOKING	Page 4	6.2.	100-mm FORKS	Page 6	10.7.3.	SLIDE BLOCK CHECK	Page 10
4.2.	FASTENING LOWER HOOKS	Page 4	6.3.	80-mm FORKS	Page 6	10.7.4.	GASKET REPLACEMENT	Page 10
4.2.1.	WITH SHIFTING	Page 4	7.	CHECKS AND ADJUSTMENTS	Page 6	11.	TROUBLESHOOTING	Page 10
4.2.2.	WITHOUT SHIFTING	Page 4	8.	DAILY CHECKS	Page 7	12.	NOISE	Page 11
4.3.	CONNECTING HOSES	Page 4	9.	REGULAR MAINTENANCE	Page 7	13.	RECYCLING	Page 11
4.3.1.	WITHOUT SHIFTING	Page 4	10.	EXTRAORDINARY MAINTENANCE	Page 8	14.	WARRANTY	Page 11
4.3.2.	WITH SEMI-INCORPORATED SHIFTING	Page 4	10.1.	FORK SUPPORT DISASSEMBLY	Page 8	15.	FACSIMILE OF CERTIFICATE OF CE CONFORMITY	Page 11

USE AND MAINTENANCE MANUAL

1. RECOMMENDATIONS FOR USING THE EQUIPMENT

1.1. PROHIBITED MOVEMENTS

Transporting an unstable or uncentred load; of weight greater than the indicated capacity; moving an already deposited load using the load to be deposited; using the attachment when it presents structural deformations or operating anomalies.

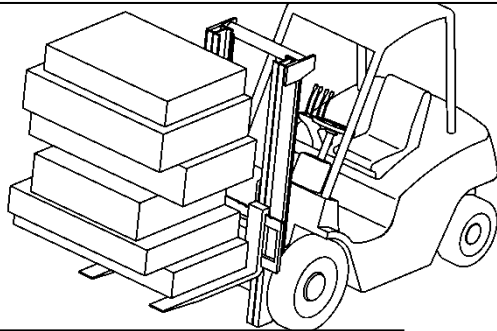

Executing movements or manoeuvres with load raised to a high level.

Proceeding at high speed on a rough surface or climbing ramps.

Transporting persons or performing manoeuvres with persons in the radius of action of the truck.

Parking the truck with motor running and/or load lifted on a rough surface or on climbing ramps.

Avoiding lifting the load with just the point of the forks. Avoid locking the pallet by opening or closing the forks. If this manoeuvre is necessary, do not tighten at full power.

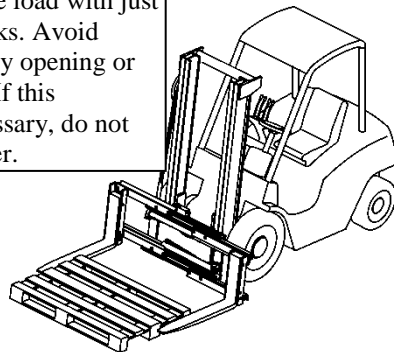

1.2. CORRECT MOVEMENTS

The load must be stable, with crossed layers or tied with straps.

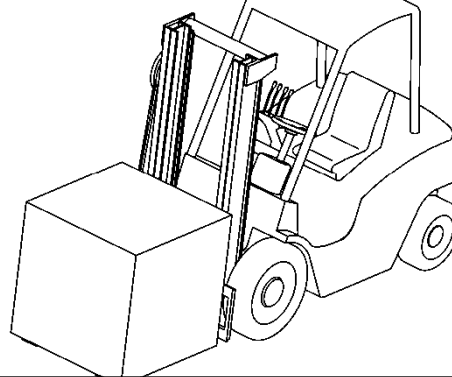

When moving with the truck, keep the mast tilted (the point of the forks high), the load lifted slightly from the ground and centred, adjusting the speed based on the road surface and any obstacles or presence of persons on the route.

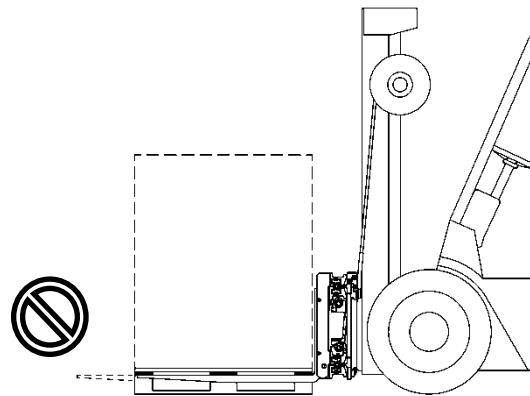

Handle loads whose height does not interfere with visibility during the manoeuvre.

The points of the forks must support the last crossbeam of the pallet without projecting beyond it.

2. CHECKS OF THE TRUCK

When checked at the distributor, the truck's hydraulic pump must have a maximum pressure of 25 MPa and a flow-capacity of 18-20 l/m'.

The recommended diameter for any additional power plant is 9.5 mm.

Distributor with no. 4 levers for controlling movement.

The fork placement notches must be in good condition and not clogged.

The fork-holder plate must be flat and without front projections.

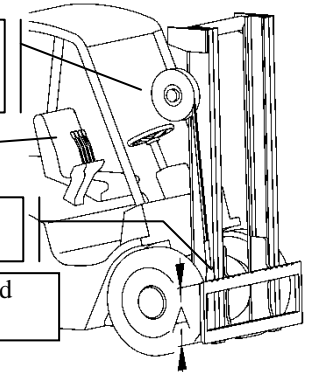

ISO 2228 Dimension "A" (mm):
Class I = min. 304 – max. 305
Class II = min. 380 - max. 381
Class III = min. 474.5 – max. 476
Class IV = min. 595.5 – max. 597

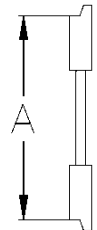

DO NOT USE THE ATTACHMENT FOR ANY PURPOSE OR MOVEMENT OTHER THAN INDICATED.



THE EFFECTIVE CAPACITY OF THE COMBINATION OF THE TRUCK AND THE ATTACHMENT IS THE RESPONSIBILITY OF THE MANUFACTURER OF THE TRUCK AND MAY NOT CORRESPOND TO WHAT IS SPECIFIED ON THE IDENTIFICATION PLATE. CONTACT THE MANUFACTURER OF THE TRUCK FOR ITS DEFINITIVE CAPACITY.

USE AND MAINTENANCE MANUAL

3. ATTACHMENT DESCRIPTION

3.1. SHIPPING CONFIGURATION

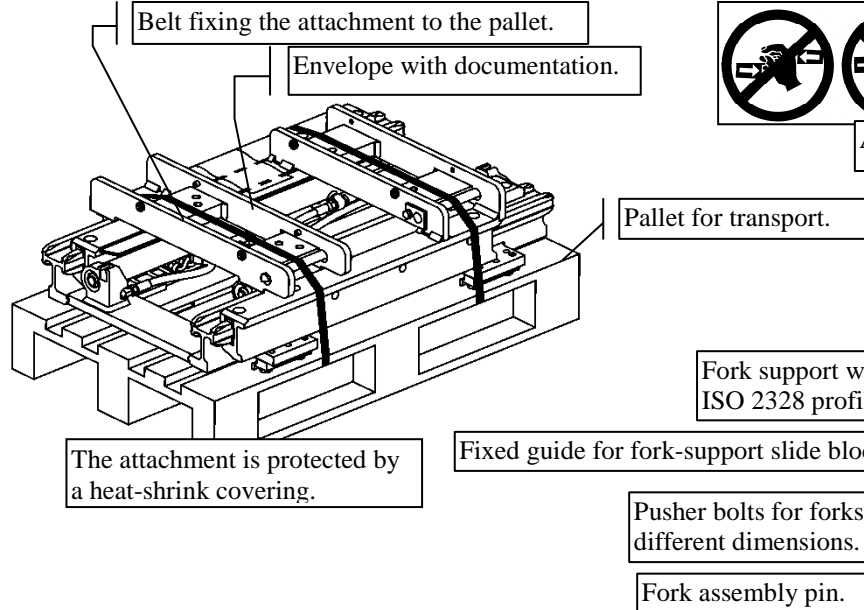

3.2. FRONT DESCRIPTION

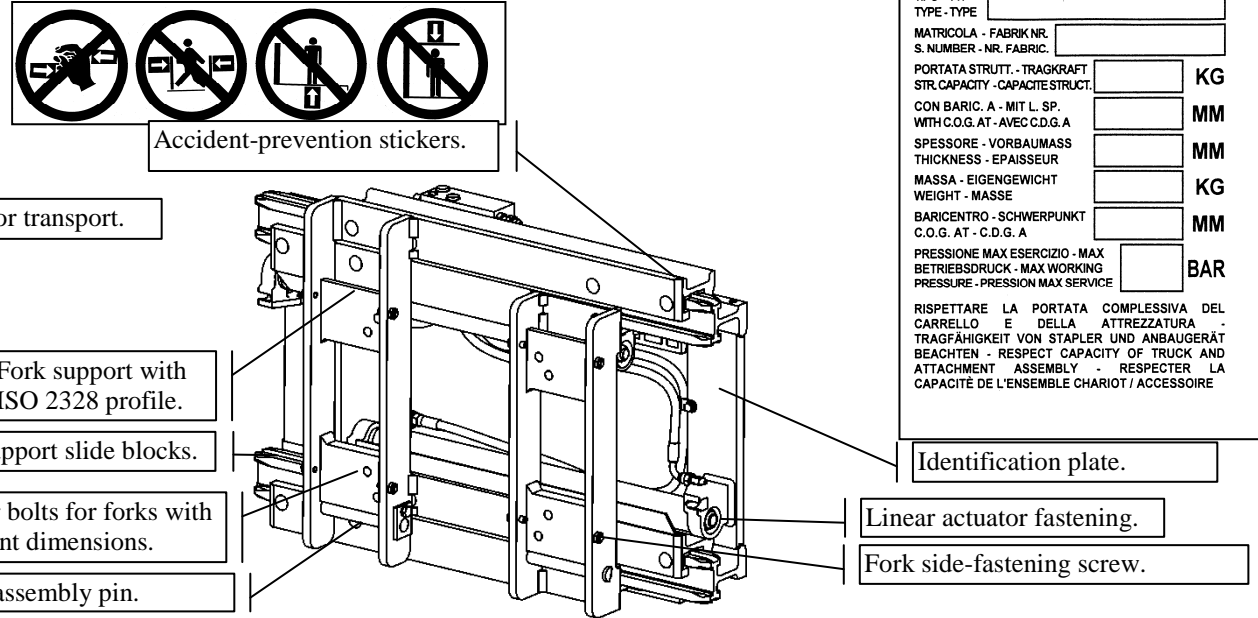

3.2.1. REAR DESCRIPTION WITHOUT SHIFTING

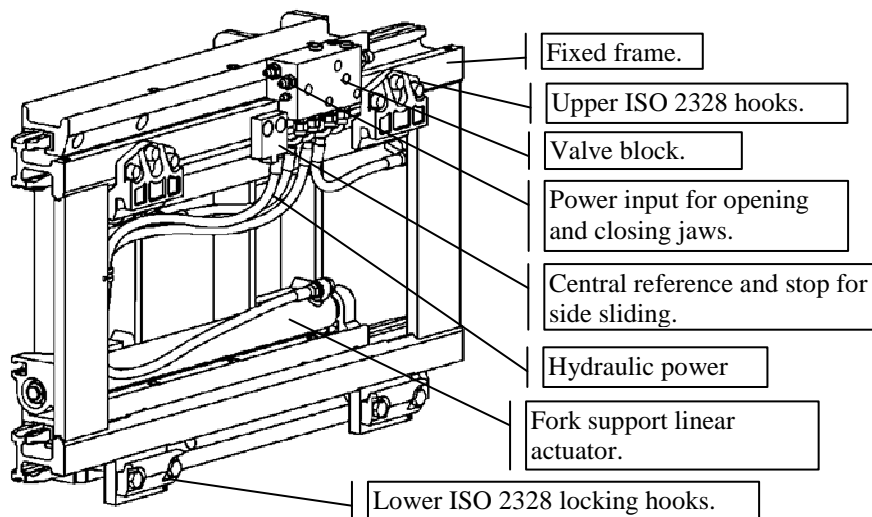

3.2.2. REAR DESCRIPTION WITH SHIFTING

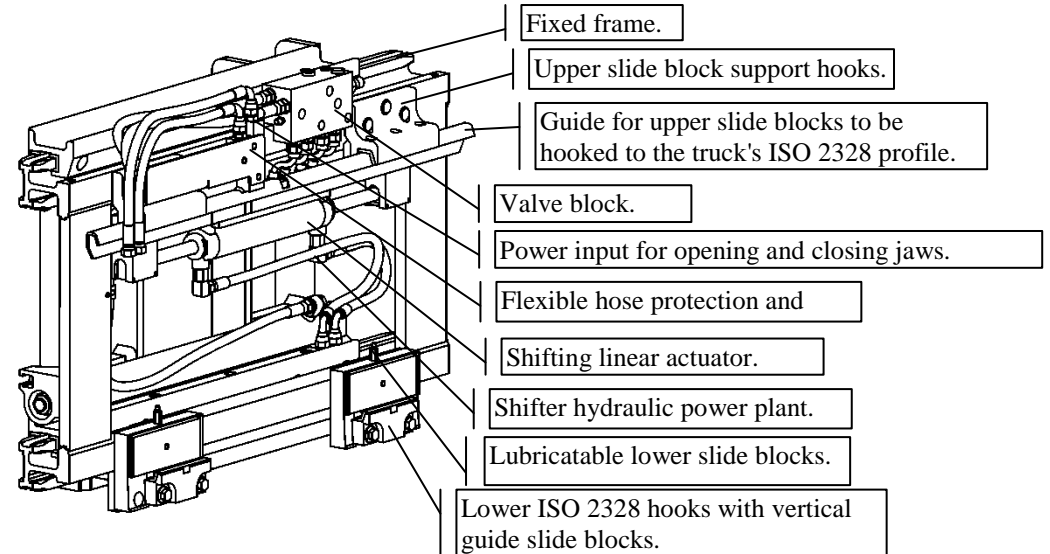

USE AND MAINTENANCE MANUAL

4. FIXING TO THE TRUCK

4.1. HOOKING

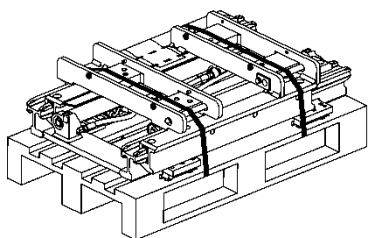

- 1) Remove the Nylon protection and the fastening belts.
- 2) Fasten the eyebolts to the ends of the frame.
- 3) Disassemble the lower hooks. Wrench ISO 2936.
- 4) Use cables with UNI ISO 4479 hooks to lift the attachment.
- 5) Hook the attachment to the truck so that the central stop engages the central notch of the fork-holder plate.

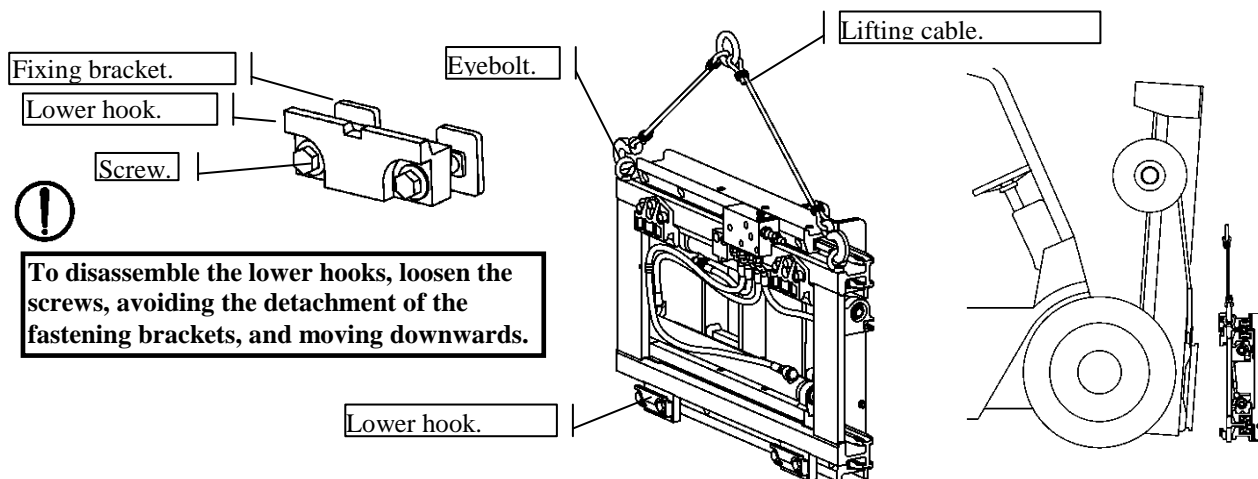

4.2. FASTENING LOWER HOOKS

Use ISO 3318 hexagonal wrench (mm)/(N/m):
Class 2 = 22/120; Class 3 = 24/200; Class 4 = 24/200.

4.2.2. WITHOUT SHIFTING

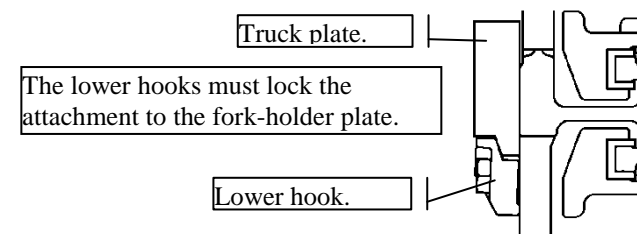

4.2.1. WITH SHIFTING

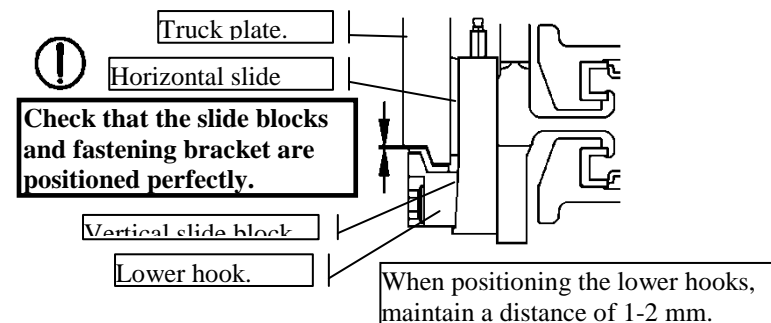

4.3. CONNECTING HOSES

! YOU MUST APPLY A PROTECTION OR DEVICE TO THE JAW-OPEN CONTROL LEVEL TO AVOID ACCIDENTALLY PUSHING IT AND LOSING THE LOAD. THE MANUFACTURER OF THE TRUCK, OR THE INSTALLER, IS RESPONSIBLE FOR APPLYING THIS DEVICE.

4.3.1. WITHOUT SHIFTING

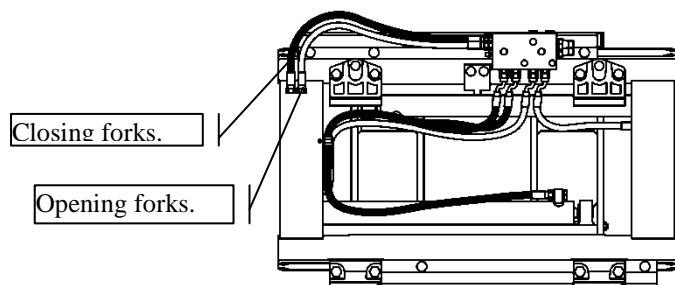

4.3.2. WITH SEMI-INCORPORATED SHIFTING

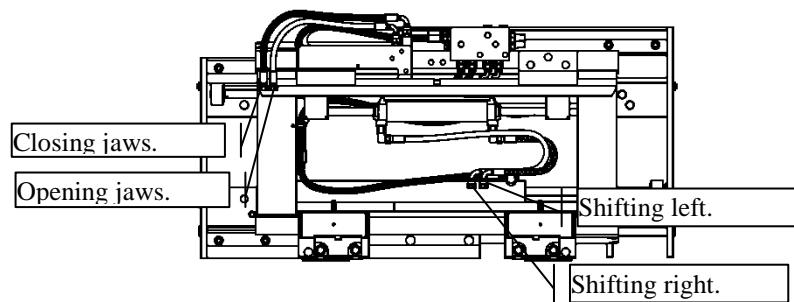

! Before connecting the hoses, eliminate the pressure in the truck's circuit following the manufacturer's

! Oil can spill out of the hoses. Prepare a container to collect the fluid.

! The connection hoses between valve and truck power plant are options.

USE AND MAINTENANCE MANUAL

5. HYDRAULIC POWER PLANT

! YOU MUST APPLY A PROTECTION OR DEVICE TO THE JAW-OPEN CONTROL LEVEL TO AVOID ACCIDENTALLY PUSHING IT AND LOSING THE LOAD. THE MANUFACTURER OF THE TRUCK, OR THE INSTALLER, IS RESPONSIBLE FOR APPLYING THIS DEVICE.

! Before connecting the hoses, eliminate the pressure in the truck's circuit following the manufacturer's instructions.

! Oil can spill out of the hoses. Prepare a container to collect the fluid.

5.1. CONNECTION WITHOUT SHIFTING

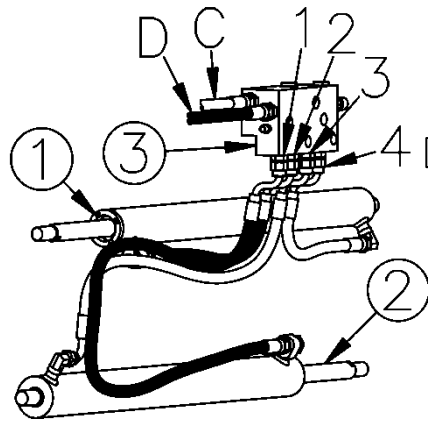

5.1.1. DIAGRAM WITHOUT CUT-OFF

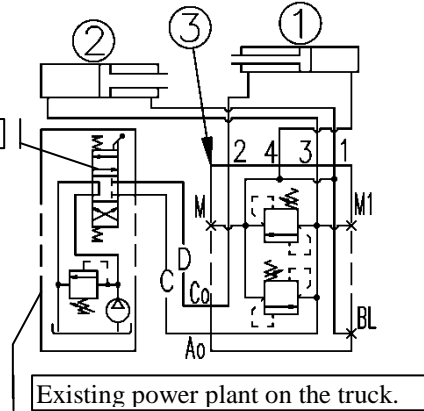

5.1.2. DIAGRAM WITH CUT-OFF CLOSED

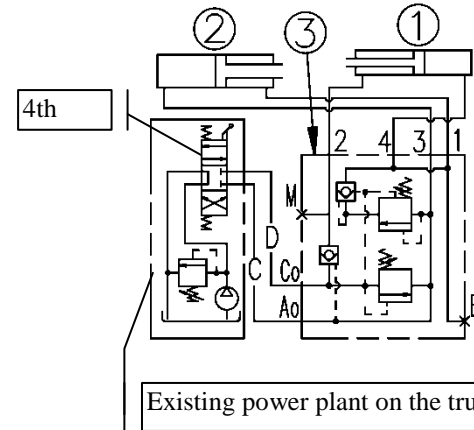

5.3. MOVEMENT CHECK

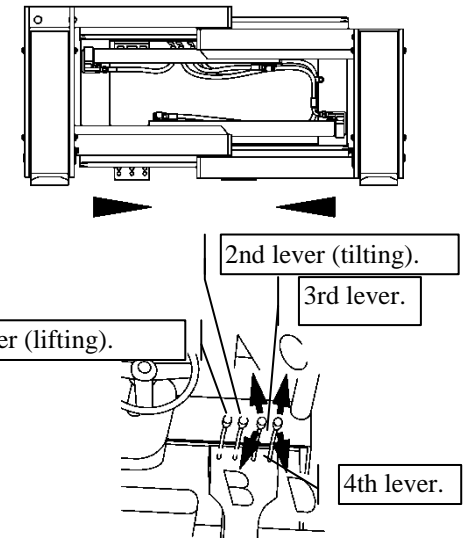

5.2. CONNECTION WITH SHIFTING

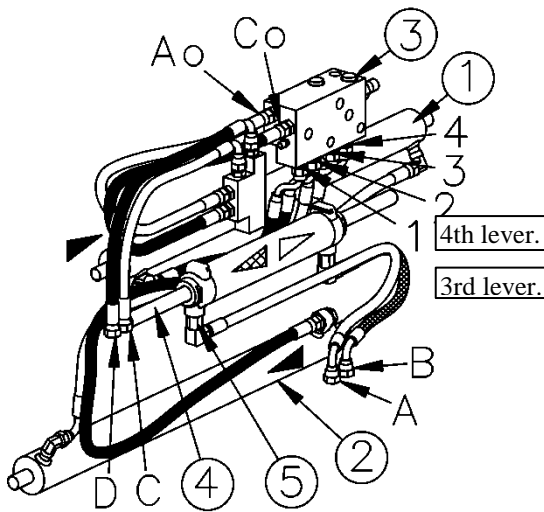

5.2.1. DIAGRAM WITHOUT CUT-OFF

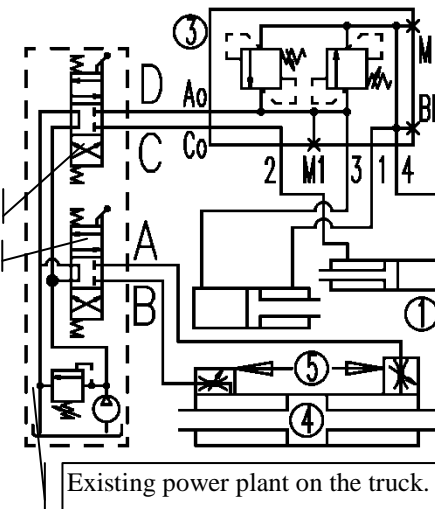

5.2.2. DIAGRAM WITH CUT-OFF CLOSED

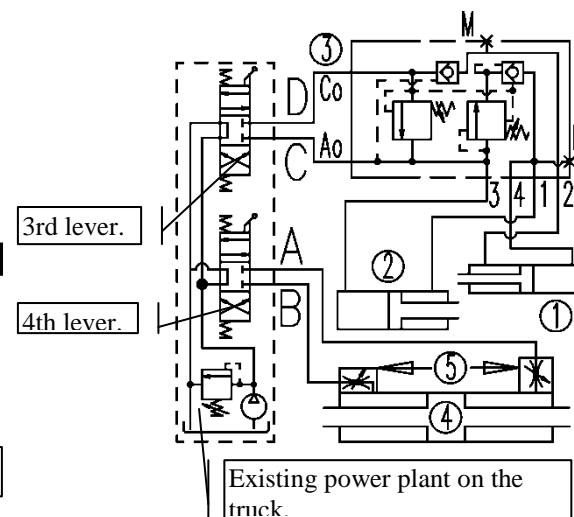

! To check the connections, perform 5 complete movements without and with a load.

USE AND MAINTENANCE MANUAL

6. MOUNTING THE FORKS

6.1. 130-mm FORKS



Be careful during handling, the fork is precariously balanced.



For narrower forks, you must use a 12-mm ISO 2936 wrench to reposition the push bolts located in the lower part of the fork support. Use a 6-mm ISO 2936 wrench to insert the replacement plugs to protect the remaining free holes.

1) Use a 17-mm ISO 3318 wrench to slide out the stop pin holding the lower jaw.

2) Use a 16-mm ISO 3318 wrench and a 5-mm ISO 2936 wrench to open the side fork

3) Hook the fork to the upper ISO 2328 profile of the fork support and rest it on the lower part.

4) Slide the lower jaw stop pin and lock with the screw.

5) Lock the fork with the side fastening screws.

Use straps for handling the fork.

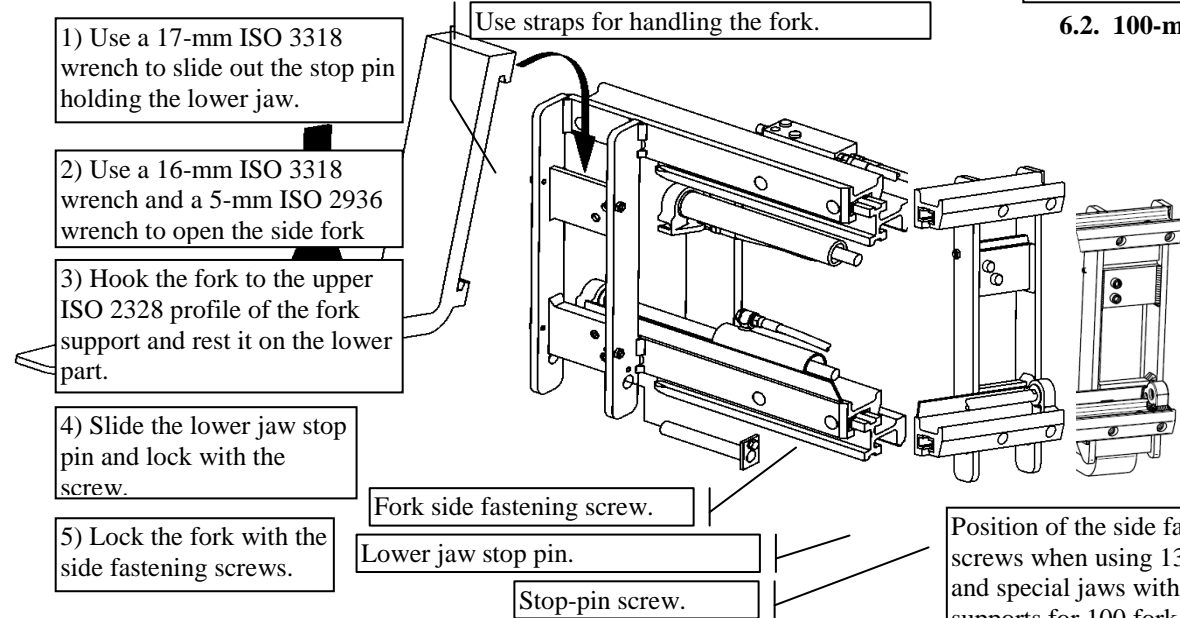

Position of the side fastening screws when using 130 mm fork and special jaws with 145 mm supports for 100 fork. 140 mm

6.2. 100-mm FORKS 6.3. 100-mm FORKS 6.4. 80 mm FORKS; 110 mm HOOK SPECIAL JAWS SPECIAL 145 MM

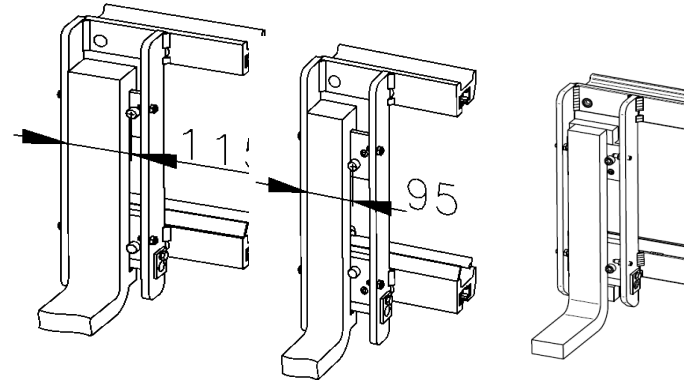

1) Position the screws as shown above.

1) Mount the forks as shown in point 6.1. MOUNTING THE FORKS.

7. CHECKS AND ADJUSTMENTS



The attachment does not have a pressure-limiter valve. Using a manometer at the distributor, or consult the specifications of the truck, to check that the pressure does not exceed 23 MPa. In the case of problems, contact our post-sales support.



The forks are synchronised by a closed circuit between the linear hydraulic actuators. The synchronism restore valves are preset and checked during final acceptance testing with in-house controllers.



With the application of the manometer, you only check/record the pressure in the hydraulic circuit for the automatic restoration of fork synchronism.



Before connecting the hoses, eliminate the pressure in the truck's circuit following the manufacturer's instructions.

Synchronism restore valves.

Point for applying manometers to check the synchronism restore valves.

Fitting for the removal of any residual air in the closed circuit between linear hydraulic actuators.



Possible spilling of oil under pressure during the removal of residual air.

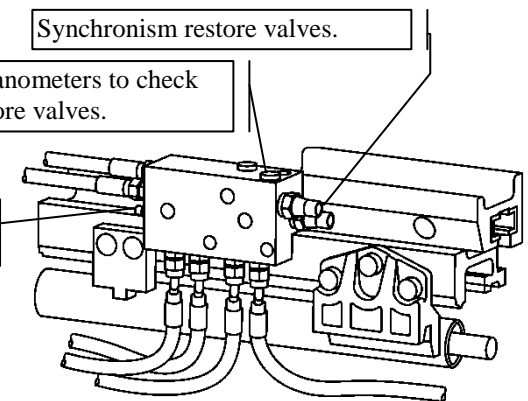

The protection of the valves is an anti-tampering safety feature. The manufacturer will not be liable for damage or breakage if not contacted before any adjustments.

USE AND MAINTENANCE MANUAL

8. DAILY CHECKS

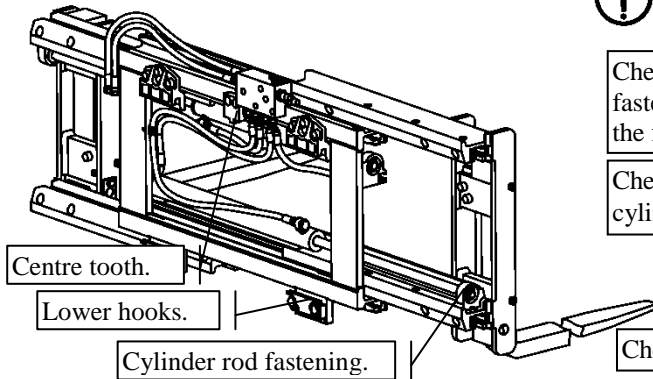

! At the start of every work shift, check the points to the side and inform maintenance personnel of any problems.

Check the tightness of the nuts fastening the rod and bottom of the fork movement cylinders.

The attachment's centre tooth must engage the centre notch of the truck's fork-holder plate.

Check for any oil leaks from the cylinders or hydraulic power plant.

Lower hooks correctly positioned, see point 4.2.

The forks must be hooked in the upper part and the lower pin correctly positioned and fastened.

Check the cleanliness of the guides or slide block tracks and lubricate

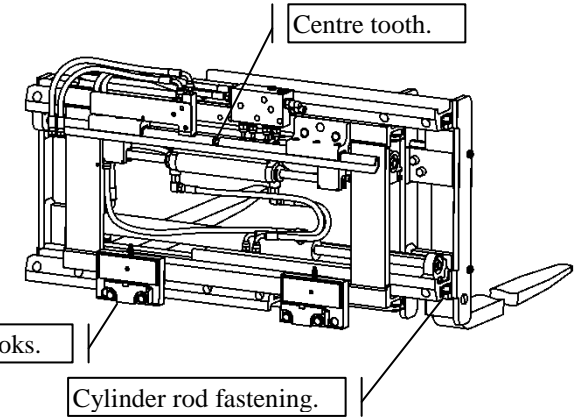

9. REGULAR MAINTENANCE

! Before connecting-disconnecting the hoses, eliminate the pressure in the truck circuit following the manufacturer's instructions.

PERIODIC MAINTENANCE DIAGRAM		
OPERATIONS	Hours of work	
Clean and grease slide-block guides "a". Grease points "a1".	200	
Check screw tightness and oil leaks from the hydraulic connections.		
Check that the nameplates and accident-prevention stickers in "c" are intact and easy to read.		
In addition to the operations for every 200 working hours, do the following:		
Check slide blocks "b" and replace if necessary.	1000	
Check the synchronism of the jaws.		
Check the condition of the flexible hoses and fittings.		
Check hydraulic actuators "d"; check for oil leaking from the plug and the condition of the chromed surface of the rod.	2000	
In addition to the operations for every 200 and 1000 working hours, do the following:		
In zone "f", check for wear on the parts sliding on the ground.		
Check the integrity of fork support base "e".	2000	
Look Position "a1" ball-head greasers UNI 7763-AM6-5.8.		



Recommended Lubricants:
For insides: ISO X M2 (SHELL ALVANIA GREASE R2). Outsides: ISO CB 32 (ESSO NUTO32).



Check the wear of the forks per the ISO 5057 standard.

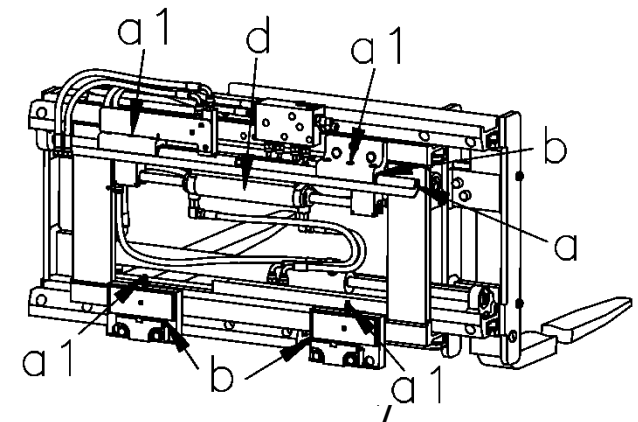

USE AND MAINTENANCE MANUAL

10. EXTRAORDINARY MAINTENANCE

10.1. FORK SUPPORT DISASSEMBLY



Attachment fixed to the truck or positioned so that you can move the fork supports hydraulically.



The balance of the support fork becomes unstable when not guided by the frame.

1) Dismount the forks.

2) Bring the jaws to their maximum

3) To disconnect the cylinder rods, use a 19-mm ISO 3318 wrench to clamp the shaft and a 30-mm ISO 1174 30 wrench to



With the rod released, the cylinders can tilt downwards.

4) Bring the cylinders to their minimum closure.

5) Using straps, slide the fork support sideways and rest it on the ground.

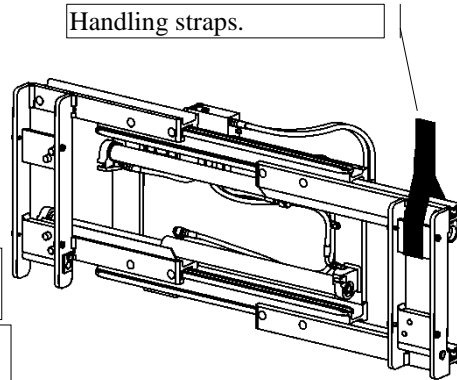

Stop fastening

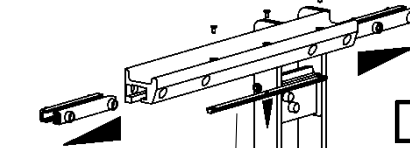

Slide block stop.

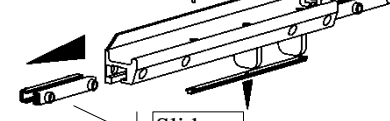

Slide

1) Use a 4-mm ISO 3926 wrench to remove the screws and remove the slide block stop.

2) Using an 8-mm DIN 6450 punch, unlock the slide blocks and slide them off of the guide.

In the absence of holes for unlocking the slide blocks, use an ISO 2380 screwdriver.



Position the stop correctly when mounting the new slide blocks.

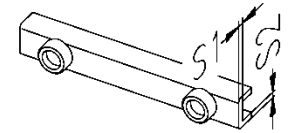

Replace the slide blocks if there is breakage or permanent deformation or if their thickness at S1 is less than 4 mm; at S2 5 mm.

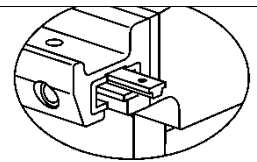

TO PUT BACK THE DISASSEMBLED PARTS, PERFORM THE PROCEDURE DESCRIBED ABOVE IN REVERSE.

10.3. CYLINDER DISASSEMBLY



Before connecting-disconnecting the hoses, eliminate the pressure in the truck circuit following the manufacturer's instructions.



Oil can spill out of the hoses. Prepare a container to collect the fluid.



Attachment fixed to the truck or positioned so that you can move the jaws hydraulically.

1) Dismount the forks.

2) Position the jaws at their minimum opening + 1000

3) Disconnect the cylinder rods using a 19-mm ISO 3318 wrench to clamp the rod and a 30-mm ISO 1174 socket wrench to unscrew the nut.

4) Bring the cylinders to their minimum closure, supporting the upper cylinder.

5) Disconnect the flexible hoses with a 19-mm ISO 3318

6) Use a 30-mm socket wrench to unscrew the bottom-side nut and remove the cylinder.

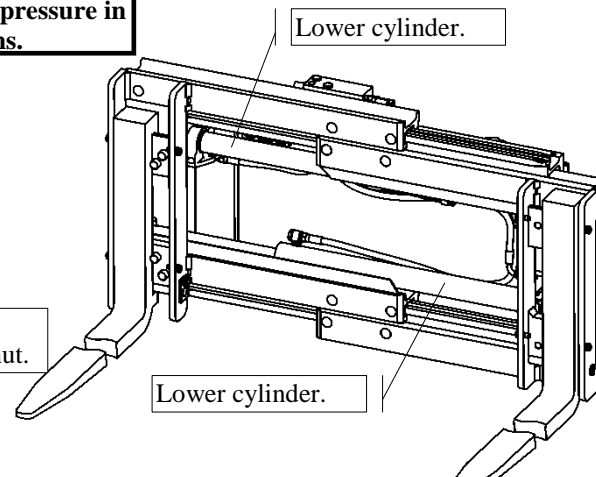

TO PUT BACK THE DISASSEMBLED PARTS, PERFORM THE PROCEDURE DESCRIBED ABOVE IN REVERSE.

10.4. REPLACING GASKETS

Use a 19-mm ISO 3318 wrench to replace the copper seal washer.

Plug with copper washer for the hydraulic seal.

Cylinder plug.

Use a 12-60-mm spanner wrench and 4-mm-diameter pin to remove the cylinder plug.

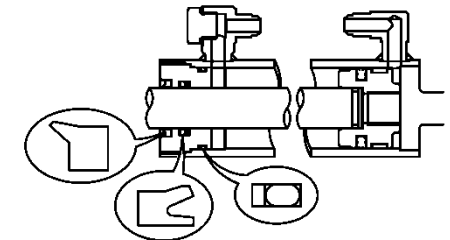
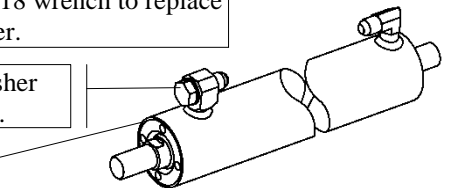

When replacing the gaskets, taken care to match the mounting direction and work in an area protected from dust.

USE AND MAINTENANCE MANUAL

10.5. CYLINDER FASTENING

10.5.1. ROD SIDE

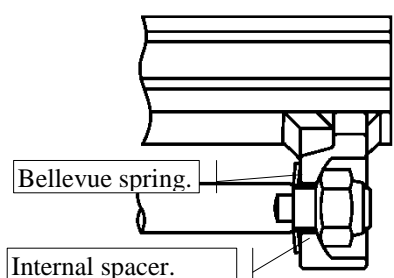

Check that the internal spacer is positioned correctly. Tighten the nut until the Bellevue spring is locked and tighten 90°.

10.5.2. BOX SIDE

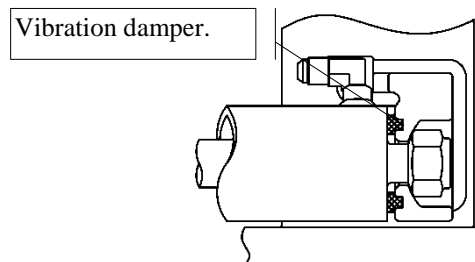

Check that the shock absorber is perfectly inserted in its seat and tighten until the cylinder is locked.



TO PUT BACK THE DISASSEMBLED PARTS, PERFORM THE PROCEDURE DESCRIBED ABOVE IN REVERSE.

10.7. SIDE-MOVEMENT MAINTENANCE

Before connecting-disconnecting the hoses, eliminate the pressure in the truck circuit following the manufacturer's instructions.

Oil can spill out of the hoses. Prepare a container to collect the fluid.

10.7.1. UNHOOKING FROM THE TRUCK

You must disconnect the attachment from the truck for maintenance.

1) Apply no. 2 eyebolts and hook with cable.

2) Dismount the lower hooks with an ISO 3318 wrench.

3) Disconnect the flexible hoses from the truck.

4) Disconnect the attachment from the truck and rest it on the ground.

Fixing bracket.

Lower hook.

Screw.

Lifting cable.

Eyebolt.

Lower hook.



To disassemble the lower hooks, loosen the screws, avoiding the detachment of the fastening brackets, and moving downwards.

UM-SSFGA-10-2010-R1

10.6. VALVE DISASSEMBLY

You must disconnect the attachment from the truck to remove the valve.

Before connecting-disconnecting the hoses, eliminate the pressure in the truck circuit following the manufacturer's instructions.

Oil can spill out of the hoses. Prepare a container to collect the fluid.

1) Apply no. 2 eyebolts and hook with cable.

2) Dismount the lower hooks with an ISO 2936

3) Disconnect the flexible hoses from

4) Disconnect the attachment from the truck and rest it on the ground.

5) Disconnect no. 4 flexible hoses from the valve unit.

6) Use a 6-mm ISO 2936 wrench to disconnect or replace the valve unit.

Valve unit.

Eyebolt.

Lower hook.

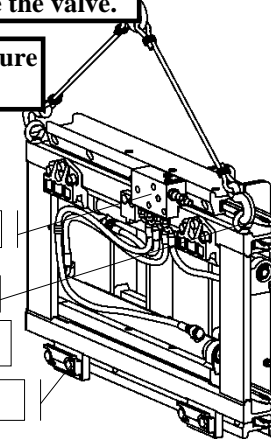

10.7.2. CYLINDER AND SLIDE BLOCK DISASSEMBLY

1) Disconnect no. 2 flexible hoses from the distribution block.

2) Use a 5-mm DIN 6450 punch to remove the elastic pins.



In this step, the cylinder block and support drop down.

3) Disconnect the cylinder from the support.

4) Use a 5-mm DIN 6450 punch to extract the upper guide slide blocks.

5) Disconnect the lower slide blocks using an ISO 2380 screwdriver.

Flexible hoses.

Upper slide blocks.

Cylinder.

Cylinder support.

Lower slide

FEM slide



TO PUT BACK THE DISASSEMBLED PARTS, PERFORM THE PROCEDURE DESCRIBED ABOVE IN REVERSE.

USE AND MAINTENANCE MANUAL

10.7.3. SLIDE BLOCK CHECK

Replace the slide blocks if there is breakage or permanent deformation or if their thickness at S1 is less than 2 mm; S2 3 mm and S3 3 mm.

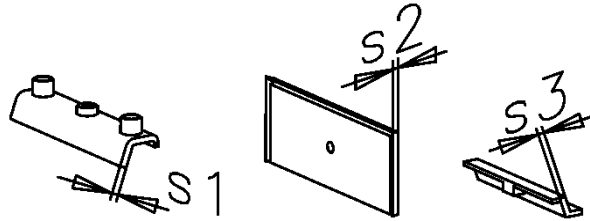

10.7.4. GASKET REPLACEMENT

Turn the plug until it is completely out of the lock ring.

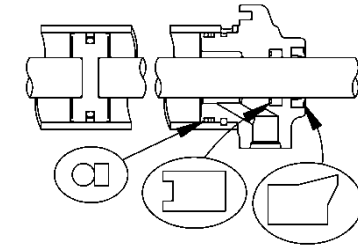
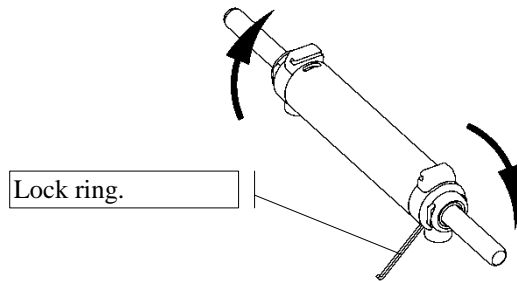

When replacing the gaskets, taken care to match the mounting direction and work in an area protected from dust.



TO PUT BACK THE DISASSEMBLED PARTS, PERFORM THE PROCEDURE DESCRIBED ABOVE IN REVERSE.

11. TROUBLESHOOTING

The jaws close or open slowly or irregularly.	Insufficient oil pressure and/or flow.	Check and/or adjust the hydraulic pump and oil level in the tank of the truck.
	Residual air in the hydraulic circuit.	Check the oil level in the forklift's tank. Remove the residual air in the circuit.
	Hydraulic pump worn.	Replace the truck's hydraulic pump.
	Obstruction or leaks in the hydraulic circuit.	Check the hoses and connections of the hydraulic power plant of the truck-attachment; remove the obstructions or leaks, replacing damaged hoses.
	Oil oozing in cylinders or valve.	Replace the cylinder gaskets or replace the valve.
Side shifting slow, irregular or blocked.	Excessive friction between the slide block guides.	Clean and grease. Check the integrity of the guides and remove any deformations. Check and/or replace the slide blocks.
	Insufficient oil pressure and/or flow.	Check and/or adjust the hydraulic pump and oil level in the tank of the truck. Check and adjust the attachment's valve.
	Residual air in the hydraulic circuit.	Check the oil level in the forklift's tank. Remove the residual air in the circuit.
	Hydraulic pump worn.	Replace the truck's hydraulic pump.
	Obstructions or breakage in the hydraulic circuit.	Check the hoses and connections of the hydraulic power plant of the truck-attachment; remove the obstructions or leaks, replacing damaged hoses.
	Oil oozing in cylinders or valve.	Replace the cylinder gaskets or replace the valve.
	Excessive friction between the slide block guides.	Clean and grease. Check the integrity of the guides and remove any deformations. Check and/or replace the slide blocks.

IN THE CASE OF PROBLEMS NOT DESCRIBED ABOVE, CONTACT OUR SERVICE DEPARTMENT

USE AND MAINTENANCE MANUAL

12. NOISE

13. RECYCLING



THE SPECIFICATIONS THAT FOLLOW APPLY TO THE TRUCK-ATTACHMENT UNIT.

- Acoustic pressure level of the weighted emission A in the work place, if it exceeds 70 dB(A); if this level does not exceed 70 dB(A), it must be indicated.

-The maximum value of the instantaneous weighted acoustic pressure C in the work place, if it exceeds 63 Pa (130 dB with respect to 20 µPa).

-Weighted acoustic power level A emitted by the machine, if the weighted acoustic pressure level A in the work place exceeds 80 dB(A).

14. WARRANTY

The manufacturer warrants all its products for 12 months or 2,000 working hours (which ever comes first) from the date of shipment.

If used for more than 8 hours per day, the warranty period will be reduced proportionally.

The warranty is limited to the replacement, FOB the manufacturer's plant, of those parts it acknowledges to be defective in materials or workmanship; it does not include labour or travel to replace the parts.

In addition, it is understood that the warranty is void if the problem is due to inappropriate use of the product, if it was not put into service following the manufacturer's instructions or if other than original replacement parts were used for modifications and/or repairs.

The attachment is not warranted for uses that exceed the capacities shown on the plate and in the documentation.

All attachments are covered by insurance against any damage to third parties caused by defective pieces or their incorrect functioning; damage caused by incorrect or improper use is excluded.

If replaced pieces are scrapped, their disposal must be differentiated depending on the nature of the material and in conformity with the law governing the disposal of solid industrial waste of solid industrial waste.

NOTE: Pieces not listed in the table to the side are steel.

Pallet for transport	Wood
Belts for fixing and protective covering for shipping	Polyester and heat-shrink
Cylinder plugs	Cast iron
Guide slide blocks	Nylon
Pipes/fittings	Polyester/steel
Gaskets	Polyurethane and NBR
Paint	Polyester epoxy
Gearmotor and grease	Dispose of in conformity with local law

15. FACSIMILE OF CERTIFICATE OF CE CONFORMITY

Dichiarazione CE di Conformità

Noi NOME COSTRUTTORE

INDIRIZZO COSTRUTTORE

XXXXXXXXXXXXXXXXXX

Dichiariamo sotto la nostra esclusiva responsabilità che il prodotto:

Tipo YYYYYYYYYYYYYYYYYY

Marca XXXXXXXXXXXXXXXXXX

Modello WWWWWWWWWw

Matricola JJJJJJJJJJ

Anno di fabbricazione VVVV

è conforme alle disposizioni della Direttiva Macchine 2006/42/CE e alle disposizioni della norma EN 1726-2

Persona autorizzata a costituire il fascicolo tecnico

Nome Pietro

Cognome Foroni

Posizione Direttore Ufficio Tecnico

Indirizzo 29027 Casoni di Podenzano - Piacenza (Italy)

Persona autorizzata a redigere la dichiarazione

Nome Claudio

Cognome Carnieletto

Posizione Direttore Assicurazione Qualità e Post Vendita



Piacenza, 10 dicembre 2009