

Double scissor lift tables

Model 2E/2A

Compact with high stroke

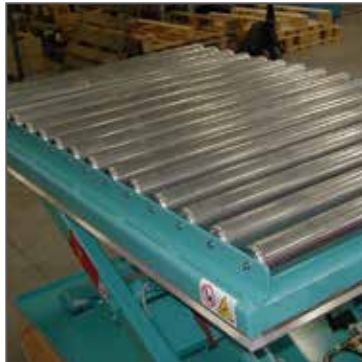

BOLZONI 

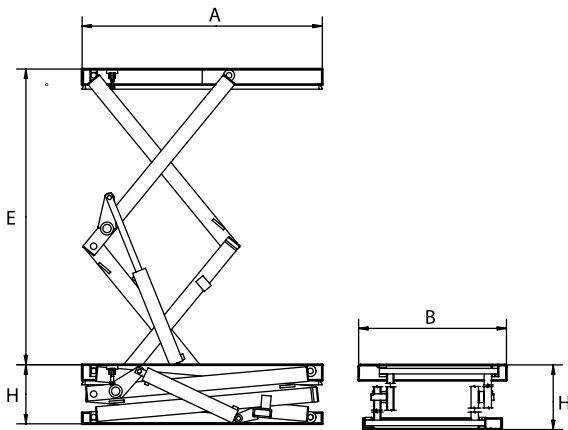

Range: 500 Kg - 3000 Kg

- Aluminium safety bar stops the descent of the platform in case of contact with obstructions
- Single acting hydraulic cylinders equipped with hose safety valve, check valve and drainage.
- Low voltage "Hold-to-run" type control box
- Mechanical block bar for safe servicing and maintenance operations
- Removable lifting eye(s) to make easier handling and installation
- Compliance with the Machinery Directive 2006/42CE and Safety Requirements for lift tables EN1570-1.

Used to achieve greater stroke without increasing the platform size, the double scissor lift tables model 2E and 2A are often used to connect one level to another.

Model	Capacity	Stroke	Platform	Collapsed Height	Motor	Cylinder
		E mm				
Type 2E for evenly distributed loads						
A2.05.E010	500	1600	1300 x 800	320	0,55	1 60
A2.05.E020	500	1600	1300 x 1000	320	0,55	1 60
A2.05.E025	500	2000	1500 x 800	350	0,55	1 60
A2.05.E026	500	2000	1500 x 1000	350	0,55	1 60
A2.05.E030	500	2000	1700 x 800	350	0,55	1 60
A2.05.E040	500	2000	1700 x 1000	350	0,55	1 60
A2.10.E010	1000	1600	1300 x 800	360	0,75	2 60
A2.10.E020	1000	1600	1300 x 1000	360	0,75	2 60
A2.10.E030	1000	2000	1700 x 800	380	1,10	2 60
A2.10.E040	1000	2000	1700 x 1000	380	1,10	2 60
Type 2A for partially concentrated loads						
A2.10.A050	1000	2500	2000 x 1000	450	1,1	2 60
A2.10.A060	1000	2500	2000 x 1200	450	1,1	2 60
A2.10.A280	1000	2900	2500 x 1000	550	3,0	2 70
A2.10.A290	1000	2900	2500 x 1200	550	3,0	2 70
A2.20.A010	2000	1600	1400 x 1000	450	1,1	1 70
A2.20.A020	2000	1600	1400 x 1200	450	1,1	1 70
A2.20.A030	2000	2000	1700 x 1000	500	1,1	2 70
A2.20.A040	2000	2000	1700 x 1200	500	1,1	2 70
A2.20.A050	2000	2400	2000 x 1000	500	1,5	2 70
A2.20.A060	2000	2400	2000 x 1200	500	1,5	2 70
A2.20.A260	2000	2900	2500 x 1200	600	3,0	2 90
A2.20.A280	2000	2900	2500 x 1500	600	3,0	2 90
A2.20.A290	2000	3500	3000 x 1500	650	4,0	2 90
A2.30.A210	3000	1500	1500 x 1200	600	3,0	1 120
A2.30.A220	3000	1800	1800 x 1200	600	3,0	2 90
A2.30.A230	3000	2300	2000 x 1200	600	4,0	2 110
A2.30.A240	3000	2900	2500 x 1200	600	4,0	2 110
A2.30.A250	3000	3500	3000 x 1500	650	4,0	2 110
A2.30.A260	3000	3500	3000 x 2000	650	4,0	2 110

CUSTOMIZED SOLUTIONS

Thanks to our experience and a wide range of accessories available, we are able to provide customized solutions to improve productivity, efficiency and safety to suit all specific requirements.

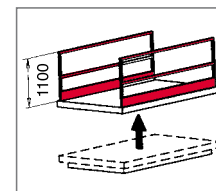

Safety handrails

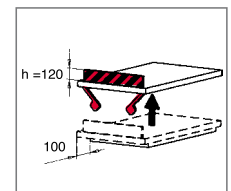

Roll-off stop

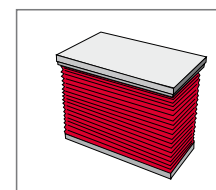

PVC bellow

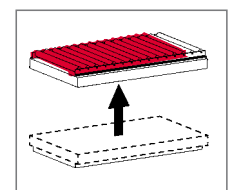

Gravity roller conveyor

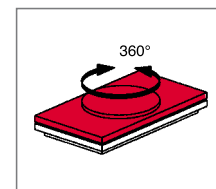

Manual circular turntable

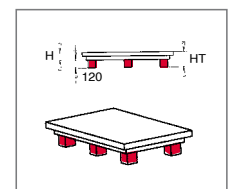

Lower frame with fork pockets

Bolzoni promotes environmental sustainable research and innovation.

For a lower impact on the environment, Bolzoni lift tables are available with biodegradable hydraulic oil on request, and are all provided with high-efficiency electric motors IE3. Lift tables are painted with water based nontoxic solvent free paint.

Bolzoni SpA lift tables facility is certified with the Environment Certificate ISO 14001:2015, since 2006.

BOLZONI S.p.A.

VIA I MAGGIO, 103 - CASONI DI PODENZANO -
29027 PIACENZA (ITALIA)

Tel. +39 0523 55 55 11 - Fax +39 0523 52 40 87

www.bolzonigroup.com - sales@bolzonigroup.com

BOLZONI