

Tilting Platform Model 1E-T

Helpful to pick out small parts from containers

GREEN LINE



This range of lift tables has been designed as a “work station” to avoid adverse ergonomic conditions by giving the best possible relation between the operator and his work area.

In order to be considered efficient, a work station must necessarily respect the worker's health and comfort.

During the manual handling of loads, avoiding for example operations where it is necessary to raise the elbows above shoulder height, or

positioning loads below the waist level or the normal sitting position, means considerably reducing risks of back injuries in addition to increasing both efficiency and productivity.

The 1E-T lift tables represent the best solution. They can also be customized thanks to a wide range of accessories to satisfy the greatest variety of uses and therefore increase their functionality and safety in specific applications.

BOLZONI 

Range: 300 Kg - 1500 Kg

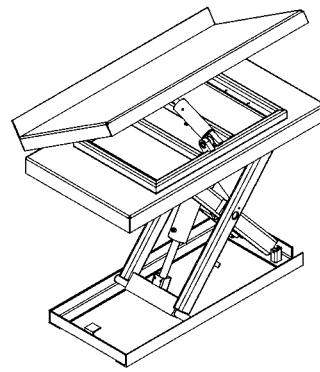
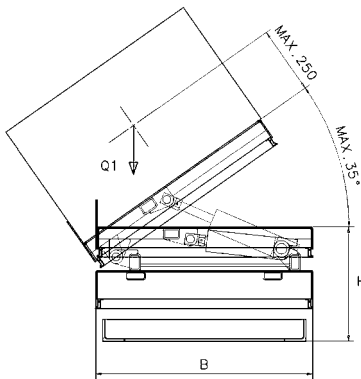

- Aluminium safety bar stops the descent of the platform in case of contact with obstructions
- 35° tilt (one way) by double acting cylinder.
- Single acting hydraulic cylinders equipped with hose safety valve, check valve and drainage.
- Maintenance props for safe maintenance operations.
- Removable lifting eye(s) to make easier handling and installation
- Low voltage (24V) control box with 5 buttons for an independent operation of the platform tilting (up-down emergency stop – up-down tilting).
- Compliance with the Machinery Directive 2006/42/CE and Safety Requirements for lift tables EN1570-1.

The new tilting platform, allowing 35° tilt, in one direction, is particularly useful during operation where small parts need to be picked out from container raised by the platform and can also find extensive use on assembly lines (car industry and components in general).

Model	Capacity	Stroke	Platform	Collapsed Height	Motor	Cylinder	Lifting Time
	Q1 kg	E mm	A x B mm	H mm	Kw	n. diam.	sec.
A1.05.E010T	300	800	1250 x 800	360	0,55	1 60	13
A1.05.E020T	300	800	1250 x 1000	360	0,55	1 60	13
A1.05.E030T	300	1000	1500 x 800	380	0,55	1 60	20
A1.05.E040T	300	1000	1500 x 1000	380	0,55	1 60	20
A1.05.E050T	300	1200	1800 x 800	400	0,75	1 60	22
A1.05.E060T	300	1200	1800 x 1000	400	0,75	1 60	22
A1.10.E010T	800	800	1250 x 800	360	0,55	2 60	26
A1.10.E020T	800	800	1250 x 1000	360	0,55	2 60	26
A1.10.E030T	800	1000	1500 x 800	380	0,55	2 60	40
A1.10.E040T	800	1000	1500 x 1000	380	0,55	2 60	40
A1.10.E050T	800	1200	1800 x 800	400	0,75	2 60	44
A1.10.E060T	800	1200	1800 x 1000	400	0,75	2 60	44
A1.10.E070T	800	1600	2250 x 800	440	1,1	2 90	37
A1.10.E080T	800	1600	2250 x 1000	440	1,1	2 90	37
A1.15.E010T	1300	800	1350 x 800	410	0,75	1 90	32
A1.15.E020T	1300	800	1350 x 1000	410	0,75	1 90	32
A1.15.E030T	1300	950	1500 x 800	420	0,75	1 90	36
A1.15.E040T	1300	950	1500 x 1000	420	0,75	1 90	36
A1.15.E050T	1300	1200	1800 x 800	430	1,1	1 90	24
A1.15.E060T	1300	1200	1800 x 1000	430	1,1	1 90	24
A1.20.E010T	1500	800	1350 x 800	410	1,1*	1 110	24
A1.20.E020T	1500	800	1350 x 1000	410	1,1*	1 110	24
A1.20.E030T	1500	950	1500 x 800	420	1,1	1 110	27
A1.20.E040T	1500	950	1500 x 1000	420	1,1	1 110	27
A1.20.E050T	1500	1200	1800 x 800	430	1,1	1 110	37
A1.20.E060T	1500	1200	1800 x 1000	430	1,1	1 110	37

*Hydraulic power pack outside

Bolzon promotes environmental sustainable research and innovation.

For a lower impact on the environment, Bolzoni lift tables are available with biodegradable hydraulic oil on request, and are all provided with high-efficiency electric motors IE3. Lift tables are painted with water based nontoxic solvent free paint.

Bolzoni SpA lift tables facility is certified with the Environment Certificate ISO 14001:2015, since 2006.

BOLZONI S.p.A.

VIA I MAGGIO,103 - CASONI DI PODENZANO -
29027 PIACENZA (ITALIA)

Tel. +39 0523 55 55 11 - Fax +39 0523 52 40 87

www.bolzonigroup.com - sales@bolzonigroup.com

BOLZONI