

4/2 Pallet Handler

4/2 Pallet Handler

Operating Instructions

4/2 Pallet Handler

Contents

Notice for the reader	5
Validity	5
Illustrations	5
Accentuated text	5
Product description	6
Product identification	6
Scope of delivery	6
Standard accessories	6
Optional accessories	6
Intended use	7
Product description	7
Functional description	8
Possible applications	8
Operator classification / qualification	9
Period of operation	9
Forklift truck requirements	9
Safety	10
Qualification of personnel	10
Overall safety	10
Personal safety	11
Product safety	12
Transport and mounting	13
Delivery and transport	13
Packaging	13
Unpacking	13
Mounting / Installation	14
Mounting and connection to the forklift truck	14
Hydraulic jumper hose connections	15
Operation	16
Initial operation	16
Initial operation	16
Pressure setting for the 'side shift' function	17
Pressure setting for the fork positioning function	18
Conducting a test run	18
Continuous operation	19
Commissioning	19
Handling (continuous operation)	19
Operational pauses	20
Short pause	20
Restarting operations	20
Decommissioning	20
Decommissioning the attachment	20
Removing the attachment from the forklift truck	21
Maintenance and servicing	22
Preventive measures	22
Regular inspections before starting work	22
Regular maintenance	23
Lubricants and lubrication points	23
Performance of regular maintenance	24
Servicing the permanent lubrication system (optional)	25
Lubrication points on the fork carriers	25
Lubrication points on the sideshift	27

Disposal	28
Disposal of the attachment	28
Addendum	29
Torque table for bolted fastenings	29
Hydraulic circuits	30
Attachments with load bearing capacity below 3500 kg	30
Attachments with load bearing capacity 4000 kg and up	31

Notice for the reader

This document contains information and the code of conduct required for safely operating this attachment. We advise reading this document completely before operating the attachment. Keep this document ready for reference at all times.

In order to operate this attachment effectively, the following aspects are covered in this document:

- Transportation of the attachment, mounting and test operation.
- Working with the attachment.
- Maintaining and servicing the attachment.

Validity

This document is valid for:

- the operating company.
- all persons working on or operating this attachment.

Illustrations

Some of the illustrations in this document show the attachment in a simplified or diagrammatic manner.

Accentuated text

Varying circumstances have been accentuated. Symbols mark important information. The following examples show the principal accents and symbols used:



These are health and safety notices!

- Warning notices point out dangers to life and limb or damage that may occur to the attachment through improper use.
-

Follow the next steps: = start of an operational sequence

1. Step, the next operational sequence.
2. Step, the next operational sequence.



This is an indication of further available information. Such references are intended to help simplify working with the attachment.

Product description

Product identification

All attachments are clearly marked with an identification plate. The identification plate is attached to the front right-hand side of the attachment as seen from the operator's driving position.

The identification plate bears the following information:

- Manufacturer and address.
- Warning notice concerning load capacity.
- Year of manufacture.
- Type.
- Serial number.
- Load capacity.
- Load centre of gravity.
- Empty weight.
- Centre of gravity.
- Lost load centre.
- Hydraulic operating pressure.
- CE mark.
- Works number, if applicable.



The identification plate must be replaced if it is missing or damaged!

Scope of delivery

The 4/2 pallet handler, called the attachment in the following, is delivered fully assembled and ready to use.

Standard accessories

The attachment is delivered without accessories.

Optional accessories

Optional accessories and spare parts are obtainable on request.

Further information covering optional accessories can be found in the documentation included with the accessories.

Intended use

This attachment is an additional piece of equipment for forklift trucks that is used instead of forks to transport two or four pallets at a time. Four load arms are moved on guide shafts and hydraulically adjusted in pairs using cylinder drives, controlled from the operator's position on the forklift truck. Each load arm is fitted with one fork that is attached with screws. Two pallets are transported on both fork pairs side by side or in front of one another.

A different application or an application in excess of the intended rating is not in compliance.

Misappropriate use in particular:

- Any kind of transportation of persons.
- Carrying loads in excess of the maximum stated on the identification plate.
- Clamping of loads between the forks.
- Displacing loads sideways that are not fully lifted off the ground.
- Operating an attachment that is not correctly mounted to the forklift truck.
- Operating a defective attachment.
- Operating an attachment on a defective forklift truck.
- Handling by unqualified persons.

Product description

The attachment is based on a robust and torsion-resistant body. The basic clamp body comprises two guide shafts on which the inner load arms are moved horizontally. The guide shafts for the outer load arms are connected to the inner load arms without clearance through shrinking and ensure the proper adjustment of the outer load arms through the high accuracy of their spacing and parallel alignment. As these guide shafts move jointly with the inner load arms, the outer load arms can be moved to the outside beyond the width of the basic clamp body.

Depending on the version, a hydraulic flow divider or chokes in the hydraulic circuit ensure adequate synchronization of the load arm pairs. For transporting pallets side by side, the spacing between the forks of a pair is maintained using pneumatic springs.

The service intervals can be significantly lengthened by installing a permanent lubrication system. The adjustment and refilling of the permanent lubrication system is described in the section „Maintenance and servicing“.

To compensate for approach inaccuracies, the attachment is equipped with a side shift device which is bolted to the back of the housing. The side shift device is fitted with a profile or axle guide system, depending on the attachment load capacity.

Functional description

The load arms carrying the bolted-on forks are adjusted horizontally with hydraulic cylinders, which are controlled from the operator's position on the forklift truck.

The spacing of the load arms or forks must be correctly adjusted to fit the respective load transport situation. The full load is always transported on all four forks. A single pallet or two pallets in front of one another are picked up with the four forks moved together. Pallets standing side by side are transported by one fork pair each. The required spacing defined between each fork pair is maintained with pneumatic springs. One pneumatic spring acts on each inner load arm. Through mechanical synchronization, the inner load arms are moved along by the outer ones once a defined fork spacing is reached.

The entire attachment can also be hydraulically sideshifted horizontally, transverse to the direction of travel as seen from the operator's driving position, so that approach and manoeuvring inaccuracies caused by the forklift truck operator can easily be compensated for.

Possible applications

With this attachment, only such loads stored on pallets or racks may be transported the external contour and dimensions as well as the load weights of which are compliant with the attachment design.

Figures A, B, and C show situations that constitute permissible attachment manipulations.

- (A) Transport of four pallets.
- (B) Transport of two pallets.
- (C) Pick-up of loads that are at a distance from one another and that must be moved closer together for transport as shown in A.

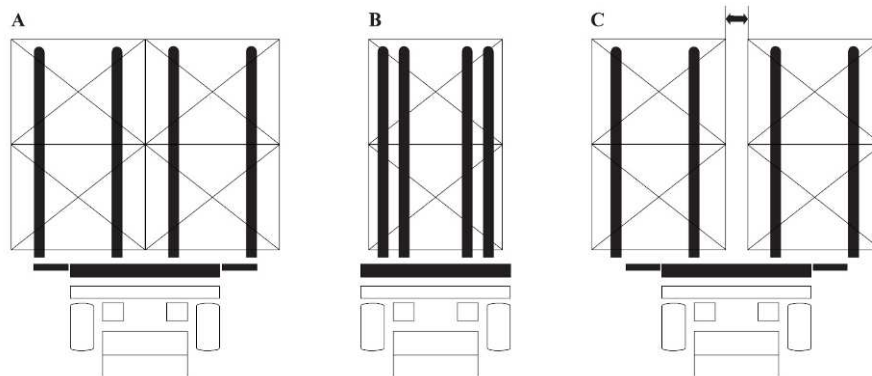

Load pick-up options

Operator classification / qualification

As an operating company, you must have adequately qualified personnel to operate forklift truck attachments. Further details on this subject can be found in the following chapters of this instruction manual.

In the case of not having qualified personnel or having further doubts on this subject, contact the manufacturer for assistance.

Period of operation

The attachment is designed for uninterrupted operation on forklift trucks.

Forklift truck requirements

The forklift truck carriage dimensions must comply with the ISO standard 2328.

The following values may help with the orientation:

- Reference dimension h3.
- Hydraulic delivery volumes.

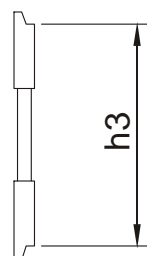

Reference dimension h3

Category ISO 2328	h3 [mm]	Load lifting capacity [kg/mm]	Oil volume [l/min]
2	381 -1	up to 1000/1200	20 ±5
3	476 -1,5	up to 1300/1200	25 ±5
3	476 -1,5	up to 2500/1200	30 ±5
4	597 -1,5	up to 3000/1200	30 ±5
4	597 -1,5	up to 4500/1200	40 ±5

ISO 2328 dimensions for h3



Smaller hydraulic delivery volumes result in lower speeds. Higher hydraulic delivery volumes result in excessive oil temperatures which will cause greater wear and lower efficiency of the hydraulic system.

Safety

Qualification of personnel

All persons working on or with the attachment must be adequately qualified to do so.

Operating personnel:

- Must have adequate instruction in the functional and operational processes.
- Knowledge of responsibilities inherent to executing the required work operations.

Service personnel:

- Well-founded knowledge of mechanical engineering, electrical engineering, and hydraulics.
- Authorisation to commission the attachment according to the relevant standards of safety technology.
- Well-founded knowledge of the structure and functioning of the attachment.

As an attachment operator, you are tasked to ensure that all persons involved in the set-up, operation, servicing, or repair of attachments have thoroughly read and understood the relevant parts of the Operating and Service Instructions.

Overall safety

This attachment complies with the state of the art of science and technology. It is dependable and safe to operate. Even so, it could still harbour possible dangers to persons, or faults may occur. Attention to the Operating and Service Instructions is therefore mandatory at all times.

The manufacturer's Operating and Service Instruction manual provides a code of conduct for the operators of attachments and for all persons involved in the set-up, operation, servicing, or repair of attachments.



Risk of injury through improper use!

Be aware that persons may be injured due to improper use. Furthermore, incorrect handling may also cause damage to the load or attachment.

- ➔ Always use the attachment for its intended purpose.
-

Personal safety



DANGER

Danger to life through crushing and shearing!

When the attachment is moved, persons can be seriously injured by crushing or shearing if caught between the load arms and in other moving parts.

- ➔ The attachment may only be activated when no persons are present within the danger zone!

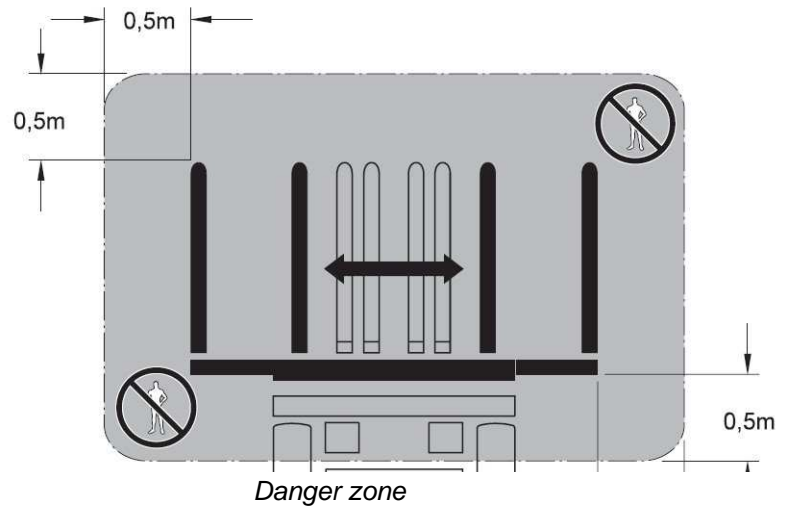

WARNING

Crushing hazard

The attachment has a substantial empty weight. This may cause dangerous crushing action during mounting or storage procedures. You may be in danger of being crushed by the empty weight of the attachment.

- ➔ Taking this into consideration, initiate the appropriate safety precautions. Further details on this subject can be found in the following chapters.
- ➔ Always safeguard the attachment against the possibility of it falling over or falling off.



WARNING

Toxicity hazards

Lubricants are harmful if brought in direct contact with the skin. Modern lubricants and hydraulic oils are optimized for technical functionality and can cause serious illness if swallowed or if they come into contact with the skin.

- ➔ Avoid all direct contact with lubricants and hydraulic fluids.

Product safety



Damage to the attachment and the load!

Incorrect handling of the attachment can result in damage to the load and the attachment itself.

- ➔ Always position the attachment properly against the load.
- ➔ Always use the attachment and its functions in the correct form and manner.

Always observe the following instructions for Figures D to I:

- (D) It is not permissible to shift the loads laterally with the 'Open' function.
- (E) It is not permissible to move loads standing off to the side with the 'Sideshift' function.
- (F) It is not permissible to pick up a load with only the forks on one side. This would result in an increased risk that the forklift truck may tip over.
- (G) Compressing or clamping loads between the load arms is not permissible.
- (H) Before transport, loads standing apart must be lifted up and moved until they come into contact by moving the load arms closer together to avoid the risk of them tipping over sideways.
- (I) The load must be flush against the rear edge of the load arm to ensure safe transport. If the nominal load is picked up with a greater distance from the load centre of gravity, the attachment will be overloaded, and there is an increased risk that the forklift truck may tip over.

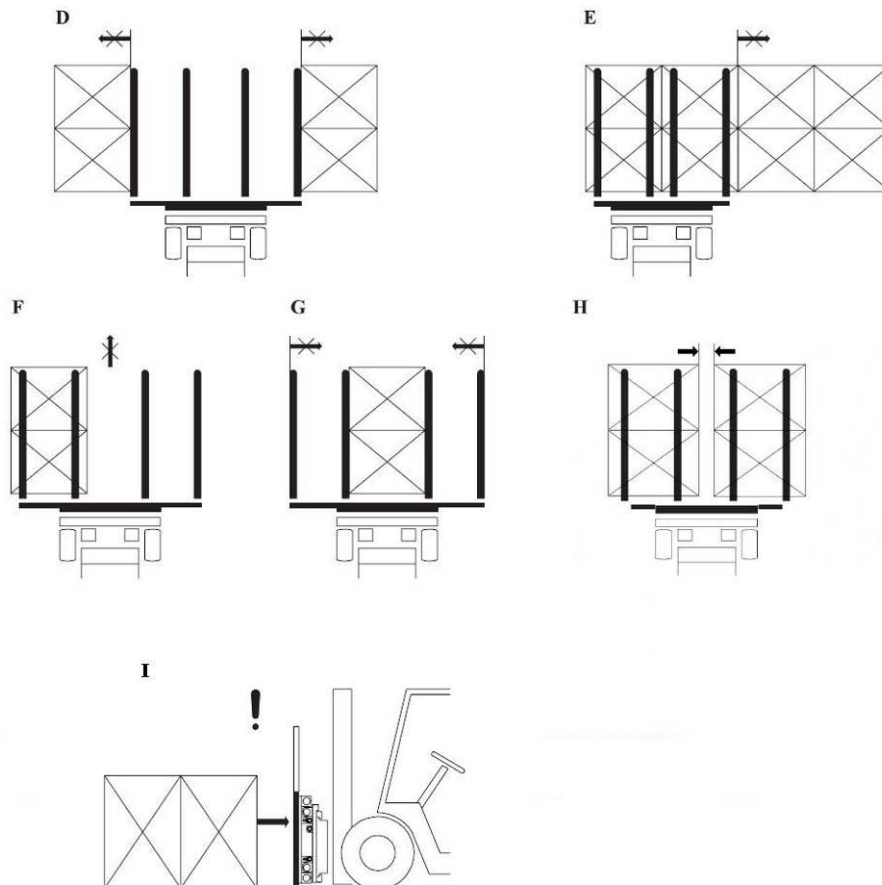

Improper handling of the attachment

Transport and mounting

Delivery and transport

The attachment is delivered on a pallet.

During transportation, the attachment must be either

- on the original pallet.
- securely mounted on the forklift truck.
- hung in appropriate lifting gear, i. e. with ropes or slings.

Packaging

Generally, the attachment is delivered on a suitable transport pallet and secured with retaining bands, but without any further packaging.

In some cases, foil packaging may be used to avoid corrosion.

Unpacking



Dangers through overturning!

After the removal of all retaining bands, the attachment is in a free standing state and could possibly tip over.

- ➔ Be sure the pallet with the attachment is on a level surface.
 - ➔ Support the attachment using lifting gear or similar before removing the retaining bands.
-

Follow the next steps:

1. Remove all existing packaging.
2. Remove the retaining bands.
3. Dispose of any packaging materials in the approved manner.

Further steps are to be taken from the following chapters.

Mounting / Installation

Mounting and connection to the forklift truck

Mounting and installation work shall be implemented by competent personnel only.

Requirements:

- Arrange the pallet with the attachment so that the forklift truck can approach it from the back.
- Make sure that the attachment cannot fall over in this position.



Environmental pollution through lubricants!

➔ Great attention must be paid in stopping hydraulic oil and lubricants from polluting the environment.

Follow the next steps:

1. Hook sling gear (1) (rope or sling) over upper guide beam (2) and deposit equipment on a support (7) (e.g. pallet).
2. Unscrew and remove the lower mounting hooks (3).
3. Position the carriage so that the centre locking pin (5) locks in the specified groove (4) on the carriage.
4. Attach lower mounting hooks (3) with bolts (6). Depending on the model, these bolts must be installed from the front of the attachment. Now tighten up the bolts with a torque wrench.
5. Connect the hydraulic jumper hoses to the attachment. Hook up the jumper hoses to the corresponding connections of the forklift truck.

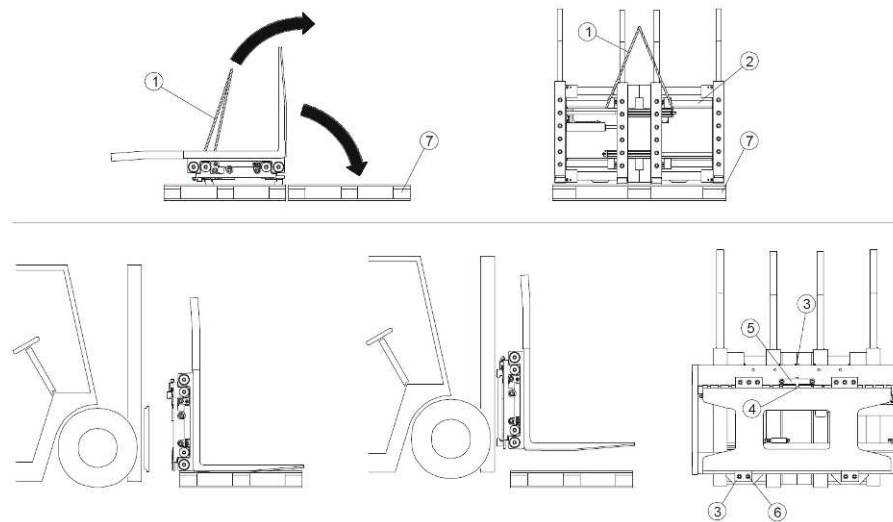

Assembly steps

6. Unscrew transport safety bolts (one or two, depending on attachment width) on the sideshift if applicable and screw into threaded holes specified for storing bolts.

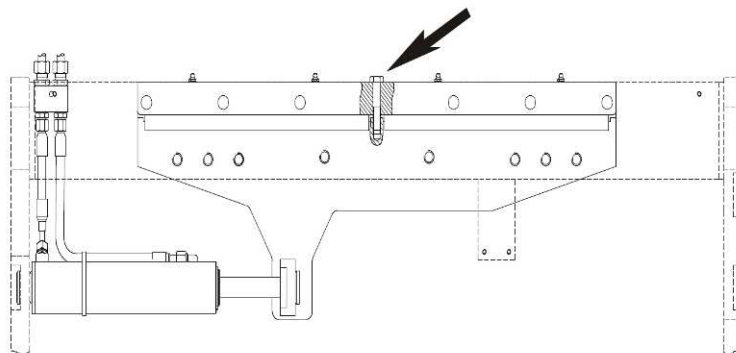

Transport safety bolts

Hydraulic jumper hose connections

Connection 1: Set fork spacing

Connection 2: Side shift

The representation of the attachment may vary depending on the model; the position of the connections is, however, identical.

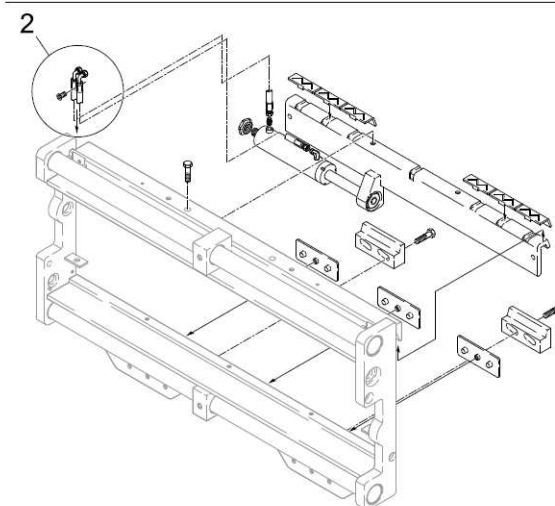
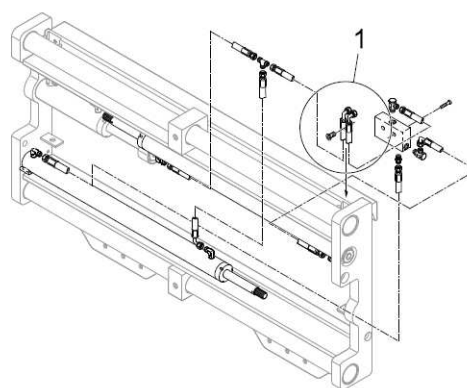

Connection diagram

Operation

Initial operation

Initial operation

Follow the next steps:

1. Check the oil level in the forklift truck, as the attachment withdraws a certain volume of hydraulic oil from the truck tank.
2. When necessary, top up the hydraulic oil.
3. Take all functions, that being all hydraulic cylinders, to the end of their travel.
4. Keep the hydraulic pressure constant for 10 seconds on each function.
5. Inspect all hydraulic couplings for leakage.
6. When necessary, retighten any leaking hydraulic couplings.
7. As an option: Activate the permanent lubrication system, see section „Servicing the permanent lubrication system (optional)“ (Page 25).

Pressure setting for the 'side shift' function

On attachments starting with a load bearing capacity of 3500 kg, the hydraulic pressure for the 'side shift' function is adjustable. The working pressure is only preset during the final inspection at the factory. The diversity of hydraulic systems and forklift trucks and the different performance rates of these systems requires individual pressure settings. In general, the max. pressure must not exceed 150 bar. This full max. pressure is not always necessary to ensure proper function, rather, the pressure setting should be adjusted to the level required for the actual job. The pressure setting screw is located on the valve block for this function. After unscrewing and removing the protective cap, the hydraulic pressure can be adjusted with a hexagon socket spanner. Rotating the adjusting screw clockwise increases the pressure, rotating counter-clockwise reduces it.

Requirements:

- Pick up a permissible load using the attachment. However, if the forklift truck identification plate specifies a lower load capacity, only loads to or below this specification may be transported!

Follow the next steps:

1. Rotate the pressure setting screw counter-clockwise all the way back.

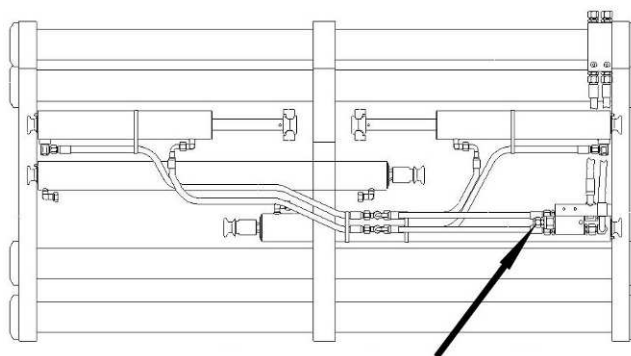

Pressure setting screw for side shift

2. Now actuate the side shift function.
3. Then, slowly rotate the pressure setting screw clockwise until the load is moving sideways at a slow but adequate speed.
4. Secure the adjusting screw with the lock nut and screw the protective cap back on.

Pressure setting for the fork positioning function

On attachments starting with a load bearing capacity of 3500 kg, the hydraulic pressure for the 'fork positioning' function is adjustable. This working pressure is only preset during the final inspection at the factory. The diversity of hydraulic systems and forklift trucks and the different performance rates of these systems requires individual pressure settings. In general, the max. pressure must not exceed 120 bar. The pressure setting screw is located on the valve block for this function. After unscrewing and removing the protective cap, the hydraulic pressure can be adjusted with a hexagon socket spanner. Rotating the adjusting screw clockwise increases the pressure, rotating counter-clockwise reduces it.

Follow the next steps:

1. Rotate the pressure setting screw counter-clockwise all the way back.

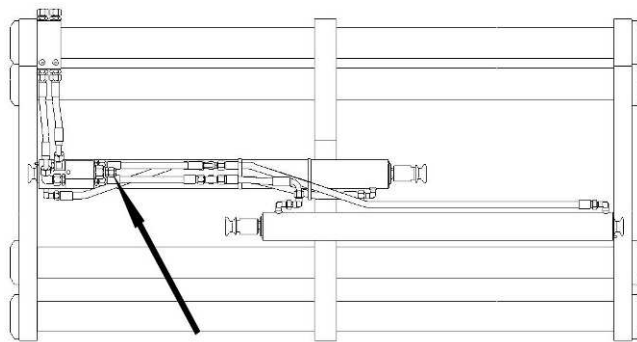

2. Then actuate the fork positioning function.
3. Slowly rotate the pressure setting screw clockwise again until a pressure of 120 bar is achieved.
4. Secure the adjusting screw with the lock nut and screw the protective cap back on.

Conducting a test run

During the test run, the verification of the load bearing capacity is to be carried out using the maximum load stated on the identification plate of the attachment. However, if the forklift truck identification plate specifies a lower load capacity, only loads to or below this specification may be transported!

Requirements:

- Choose a suitable load for the test run.
- The load chosen must be of the same type as the load to be transported during normal daily operations.

Follow the next steps:

1. Pick up the waiting load with the load arms. Ensure that both load arm pairs are uniformly loaded.
2. Lift the load picked up to approx. 30 cm.
3. Actuate the "Open" and "Close" functions and move the loads apart and back together, respectively. Actuate the "Close" function only until the loads are flush against one another.

4. Actuate the "Side shift" function, moving the attachment to each extreme end of its travel.

Should the equipment not function properly, or if leakage is found in the hydraulic system, please inform the supervising office!

Continuous operation

Commissioning

Regular checks before starting work:

- Inspect the complete hydraulic system for leaks.
- Inspect for damage to hydraulic cylinders and fittings such as hoses, pipes, valves and connectors.
- Inspect for wear and cracks in the load arms.
- Inspect for deformation of any parts; indication of a possible accident.
- Ensure that the attachment is securely seated on the forklift truck and that the retaining bolts for the upper and lower mounting hooks are screwed in tightly.

If damage is detected:

- By no means is the attachment to be used!
- Inform the appropriate supervisor responsible immediately!

Handling (continuous operation)

The attachment on its own, not attached to a forklift truck, cannot be activated and can therefore not be operated.

Because of the wide variety of forklift trucks and the differing operating functions etc., it is necessary that the operating instructions for these functions be taken from the forklift truck instruction manual.



Danger to life

- Adhere to all safety regulations.
 - Pay attention to this instruction manual.
-

The attachment may only carry loads in relation to its load centre that do not exceed the maximum load stated on the attachment identification plate.

If reduced load capacities are stated on the rating plate for forklift trucks with attachments, then these specify the maximum loads to be carried.

Suitable load types and their handling can be found in the chapter "Product description".

In case of a collision, the parts must be inspected by a competent person without delay. Deformation and cracks can lead to secondary damage.

Operational pauses

Short pause

A short pause can be defined as switching off the forklift truck to end a working day or before the start of a work break. In these or similar cases, follow the instructions in the forklift truck instruction manual.



Dangers caused by falling or slipping loads!

No loads may be resting on the load arms while the attachment is standing idle.

- ➔ Observe the instructions in the forklift truck instruction manual.
- ➔ Depressurise the attachment hydraulic system (see forklift truck instruction manual).

Restarting operations

See section „Commissioning“ (Page 19).

Decommissioning

The attachment is decommissioned e.g. if it is removed from the forklift truck to reinstall it or to mount it to a different forklift truck at a later time.

Decommissioning the attachment

Requirements:

- a suitable vessel is at hand to catch escaping hydraulic oil.
- either sawdust or a similar binding agent is at hand to absorb leaked hydraulic oil.
- a suitable transport pallet is at hand.

Follow the next steps:

1. Remove dirt and potentially leaked or spilled used lubricant from the attachment using a pressure washer. Do not point the water jet directly at the sealing elements.
2. Leave the attachment to dry in the open air or speed up the procedure by using compressed air.
3. Apply fresh lubricant specified for this purpose to all parts requiring lubrication (for suitable lubricants, see chapter "Maintenance and servicing").
4. Take all relevant moving parts through their movements to disperse the lubricant evenly.
5. Spray all blank metallic parts of the attachment with a commercial preservative intended for this purpose.
6. Switch off the forklift truck.
7. Relieve the hydraulic system pressure (see the instructions in the forklift truck manual).

4/2 Pallet Handler



8. As an option: Deactivate the permanent lubrication system. Reset all propellant units on the load arm carriers and on the side shift device to 0. For more information, refer to section „Servicing the permanent lubrication system (optional)“ (Page 25).

Removing the attachment from the forklift truck

Risk of injury through hydraulic oil spillage!

When hydraulic connections are removed or opened, hydraulic fluid can leak. Spilled hydraulic fluid causes increased slip hazards. Skin contact may cause chemical burns.

→ Wear your personal protective gear.

Follow the next steps:

1. Disconnect the hydraulic jumper hoses from the forklift truck.
2. Catch any leaking hydraulic oil with an appropriate vessel.
3. Any spilled hydraulic oil must be bound using the appropriate binding agent and disposed of in accordance with regulations.
4. Remove the bolts on the lower mounting hooks.
5. Place the attachment on the transport pallet and unhook the upper mounting hooks of the attachment by inclining the mast forward and lowering the carriage.
6. Secure the attachment on the pallet e. g. by tying it down to prevent it from accidentally falling over.
7. To safeguard against loss, refit the lower bolts and mounting hooks.
8. Store the attachment in a dry place and cover it using a suitable covering.

Maintenance and servicing

Service and repairs at regular intervals are the vital key to prolonging the useful life of the attachment.



Danger to life!

Escaping jets of high pressure hydraulic oil can cause serious injuries if the hydraulic circuit is not first depressurised before working on it!

→ Always depressurise the hydraulic circuits before performing work on the hydraulic system.



Breakdown!

→ Repairs to major functional elements such as hydraulic cylinders and valves must only be carried out by persons trained to do so.

Preventive measures

A higher rate of wear, possibly causing corrosion to the guide profiles, will result from attachments operating in extremely dirty environments, this can also have negative effects on other blank metallic surfaces, e. g. piston rods, causing leaks around the packing seals.

Quite often, dirt collecting on the attachment is caused by the front wheels of the forklift truck, which throw up dirt and grit from the road surface. It is therefore advisable to fit the truck with suitable mudguards.

Regular inspections before starting work

The following points must be accounted for before starting work:

- Leakage in hydraulic cylinders, valves, and the various other hydraulic connections.
 - Deformation and cracks in the load arms.
 - The correct mounting of the attachment on the forklift truck and especially the fastening bolts for the mounting hooks.
-



If damage is detected, inform the appropriate supervisor responsible immediately!

Regular maintenance

Lubrication and maintenance intervals are dependant on the workload of the application and external influences, e. g. the effects of dust and dirt, high fluctuations in temperature, and weather conditions.

Lubricants and lubrication points

Attention: Do not use heavy duty grease containing graphite!

For the **guide shafts of the load arms**, the following lubricants are being recommended:

- Renolit S2 (made by Fuchs)
- Interflon fin grease MP 2/3

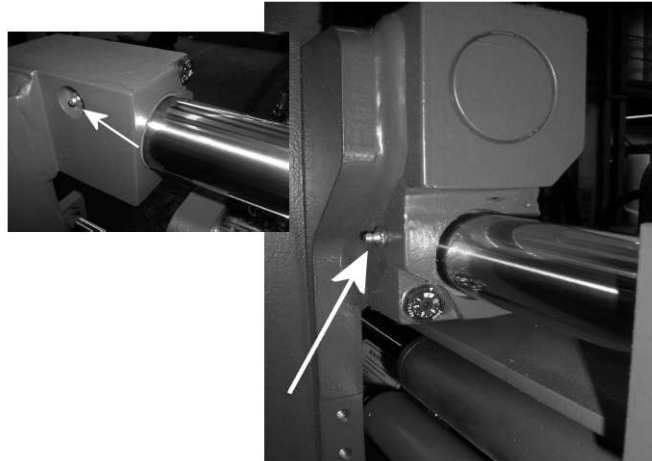

Lubrication points on the fork carriers

For the **sideshift (upper and lower slides)**, a category 2 multi-purpose grease is recommended.

For attachments with a load bearing capacity of 3500 kg or higher, the lubrication points for the 'side shift' function are lubricated exactly like those of the load arms and with the same lubricants, as the latter are also moved on chrome plated guide shafts.

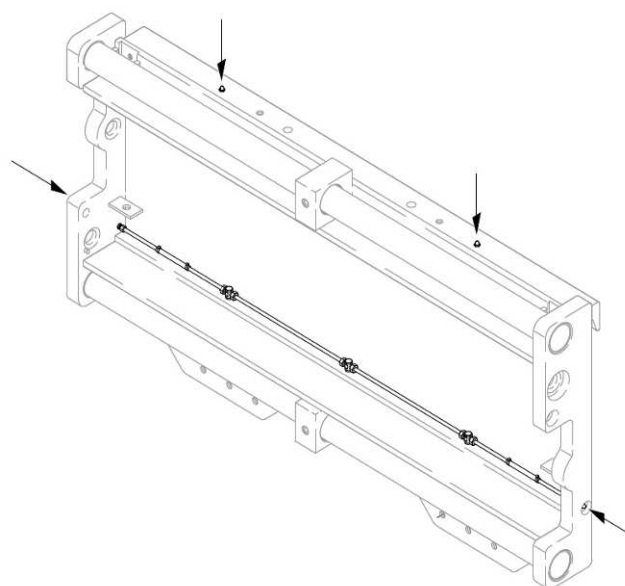

Lubrication points on the sideshift

Performance of regular maintenance

Requirements:

- The grease used must not harden when exposed to cold temperatures.

Follow the next steps:

1. Remove dirt and soiled lubricant adhering to the outside of the attachment by using a pressure washer. Do not point the water jet directly at the sealing elements.
2. Leave the attachment to dry in the open air or speed up the procedure by using compressed air.
3. Inspect the attachment for leaks in hydraulic cylinders, valves, and the various other hydraulic connections.
4. Inspect the load arms and the main frame for deformation and cracks.
5. Inspect all fastening bolts and check tightness; use a torque wrench if necessary (a torque table can be found in the addendum).
6. Apply fresh lubricant specified for this purpose to all parts requiring lubrication (for suitable lubricants, see below).
7. Take all relevant moving parts through their movements to disperse the lubricant evenly.
8. Spray all blank metallic parts of the attachment with a commercial preservative intended for this purpose.



Always give the type and serial number (see product identification label) when technical assistance or spare parts are required!

Servicing the permanent lubrication system (optional)

The permanent lubrication system contains a significantly greater lubricant quantity than the standard version. These attachments therefore have much longer service intervals. The latter may vary depending on intensity of use and external influences such as dust, high temperature variations, and weather influences, and must be adapted appropriately.

Lubrication points on the fork carriers

The layout of the lubrication nipples is identical to that of the standard version. The specification of the lubricant is also identical. Additionally, there are propellant units for permanent lubrication that are screwed into the sides of the load arm carriers.



Breakdown!

Risk of damaging the propellant unit.

- ➔ The lubricant chambers in the load arm carriers must only be refilled via the lubrication nipple after the propellant units are removed!

Follow the next steps:

1. Carry out steps 1 to 5 like you would for the standard version.
2. Unscrew and remove the used propellant unit. The latter has a knurled edge around its circumference to facilitate this. Ensure adequate disposal of the unit. It cannot be reused.



Propellant unit

3. Feed fresh grease into the lubrication point via the lubrication nipple using a grease gun until a piston shows in the assembly hole of the propellant unit. Make sure that there is still enough space left for screwing in the new propellant unit.

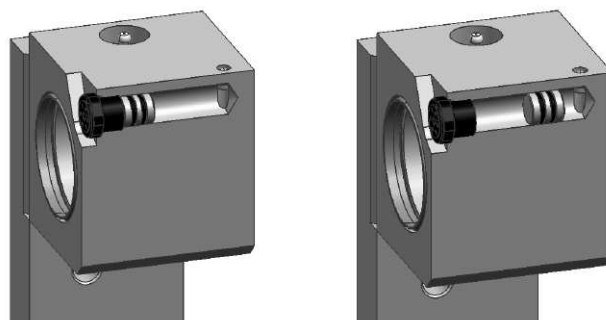

Propellant unit hole with piston

4. When the piston is visible, indicating proper completion of the refill, screw a new propellant unit into the assembly hole and tighten hand tight.

5. Then, set the propellant unit to the desired maintenance interval using a hex socket key. For this purpose, rotate the pointer to the desired number. The numbers from 1 to 12 represent the months. The propellant unit will then be active for the selected period. The default setting is 12 months, provided external conditions of use do not require shorter intervals.
6. Please repeat this exact procedure for all other lubrication points.
7. Spray all blank metallic parts of the attachment with a commercial preservative intended for this purpose.

Lubrication points on the sideshift

The upper and lower guide elements of the sideshift are supplied with lubricant via reservoirs. Attachments with a load bearing capacity of 3500 kg or higher are fitted with the same lubrication system on the sideshift as the fork carriers, as it is moved on chrome plated axles.

Follow the next steps:

1. Carry out steps 1 to 5 like you would for the standard version.
2. Unscrew the empty lubricant reservoir and replace it with a new reservoir.

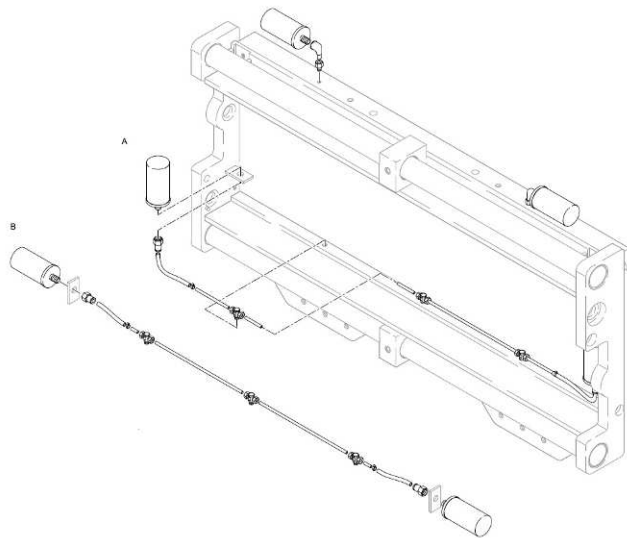

Layout of the lubrication cups

3. Each reservoir has a propellant unit. Set this propellant unit in the same manner as described for the lubrication points on the fork carriers.



Lubrication cup

4. Replace all other reservoirs and set the units as described above.
5. Spray all blank metallic parts of the attachment with a commercial preservative intended for this purpose.



If the attachment is temporarily taken out of service, reset the propellant units to the 0 position. This suspends the permanent lubrication process. After recommissioning the unit, the desired interval can be set again. The remaining service period of the propellant units is thus exploited. It is also possible to switch the propellant units to different settings as desired to adjust the lubricant quantity supplied.

Disposal

After the expiration of the assigned working period or working life has been reached, the attachment may be decommissioned and scrapped.

Disposal of the attachment

Follow the next steps:

1. Decommission the attachment, see chapter „Decommissioning“ (Page 20).
2. Take appropriate measures to ensure that the attachment is kept from being used again.
3. Dismantle the attachment professionally.
4. Separate all individual parts and scrap them according to the materials used.
5. Dispose of all surplus fluids according to regulations.

Addendum

Torque table for bolted fastenings

When tightening cylinder head and hexagon type bolts, the correct torque must be obtained by using a torque wrench.

The necessary torque requirements are classified by bolt sizes and strengths in the table below.

Old and used bolts must always be replaced by new ones.

Threads	Strength category			For Verbus Ripp 100 bolts
	8,8	10,9	12,9	
M4	3.1 Nm	4.5 Nm	5.3 Nm	---
M5	6.1 Nm	8.9 Nm	10.4 Nm	10 Nm
M6	10.4 Nm	15.5 Nm	18 Nm	18 Nm
M8	25 Nm	37 Nm	43 Nm	37 Nm
M10	51 Nm	75 Nm	87 Nm	80 Nm
M12	87 Nm	130 Nm	150 Nm	120 Nm
M14	140 Nm	205 Nm	240 Nm	215 Nm
M16	215 Nm	310 Nm	370 Nm	310 Nm
M18	300 Nm	430 Nm	510 Nm	---
M20	430 Nm	620 Nm	720 Nm	---
M22	580 Nm	830 Nm	970 Nm	---
M24	740 Nm	1,060 Nm	1,240 Nm	---
M27	1,100 Nm	1,550 Nm	1,850 Nm	---
M30	1,500 Nm	2,100 Nm	2500 Nm	---

Tightening Torque Values

Hydraulic circuits

Attachments with load bearing capacity below 3500 kg

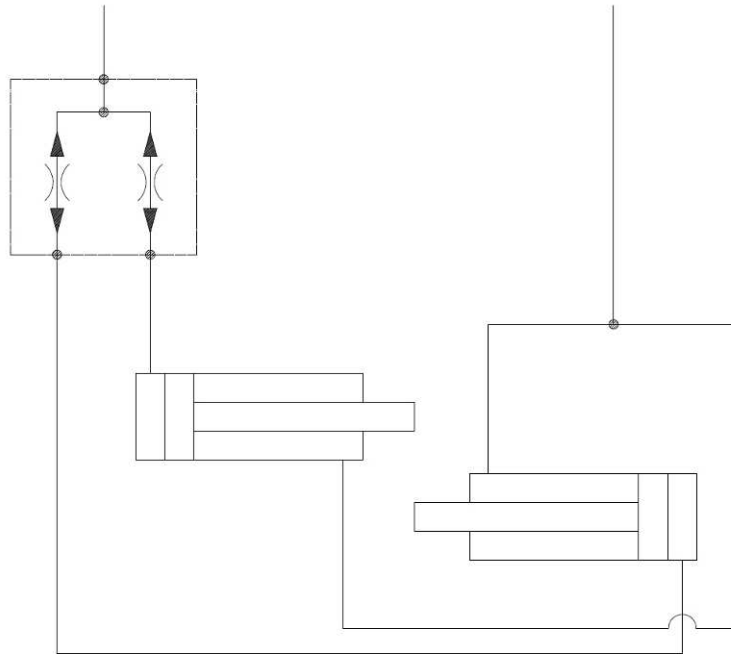

Fork positioning circuit diagram



Side shift circuit diagram

Attachments with load bearing capacity 4000 kg and up

4/2 Pallet Handler

AW-YesGB01-0510

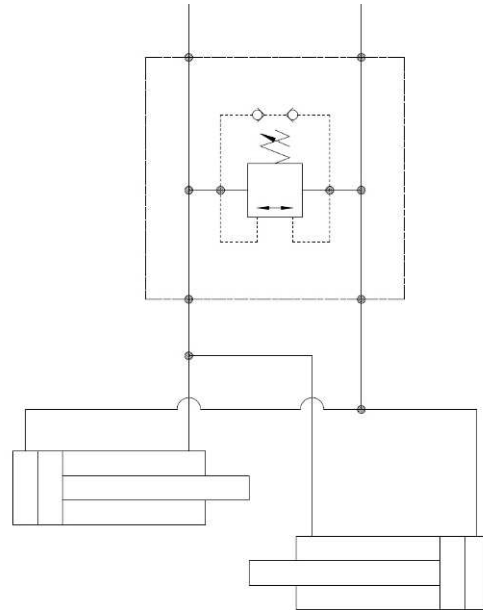

Fork positioning circuit diagram

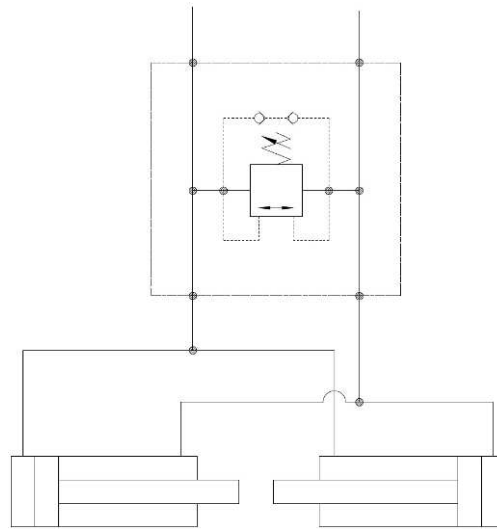

Side shift circuit diagram