

Lift Tables

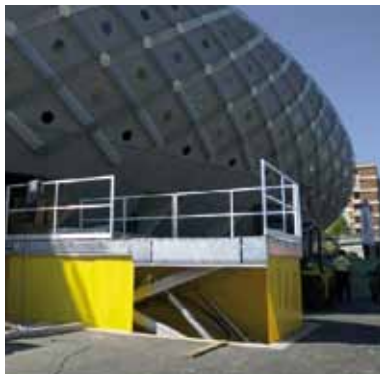



With a brand which is synonymous with specialists in forest products handling attachments, BOLZONI AURAMO offers its expertise and market leading attachments for all requirements, from large paper rolls to pulp bales and cardboard packaging, from home appliances and beverage products to construction materials.

BOLZONI AURAMO is the world's leading supplier to the main lift truck manufacturers of factory installed products.

**BOLZONI AURAMO IS
A BOLZONI GROUP'S BRAND**



**BOLZONI IS ONE OF THE
WORLDWIDE LEADING
MANUFACTURERS OF LIFT TRUCK
ATTACHMENTS, FORKS AND LIFT
TABLES, WITH THE MOST EXTENSIVE
PRODUCT CAPACITY IN THE MARKET.**

**WE ARE BOLZONI,
THE MATERIAL HANDLING GROUP**

A global reach

BOLZONI has 6 manufacturing plants located in Italy, Germany, Finland, America and China. The Group is present globally thanks to 20 direct branches with over 900 employees and independent dealers covering all continents. Since 2006 BOLZONI is listed in the Milan Stock Exchange.

Lift tables manufacturer

Bolzoni Auramo is one of the largest worldwide manufacturers of scissor lift tables. A wide range of models and capacities for application in production lines, vehicles loading, work stations in automatized lines and heavy-duty applications, providing the best solution for any specific need.

Production

Lift tables are manufactured exclusively in the Podenzano, Piacenza, Italy plant, in a dedicated area of 5.000 sqm.

Thanks to high quality components, modern production techniques and accurate final tests, Bolzoni Auramo lift tables offer a superior quality and reliability, longlife and operator safety.



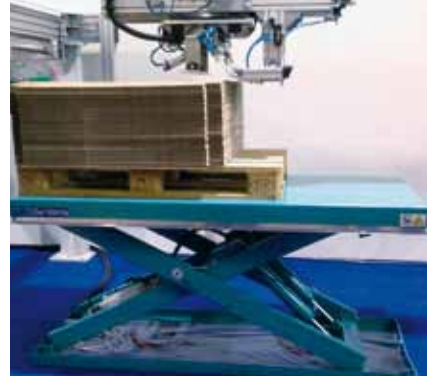

01 Single Scissor Lift Tables

Models 1E.....	pag. 10
Models 1E - T.....	pag. 11
Models A8.C.....	pag. 12
Models A8.U / A8.E.....	pag. 13
Models 1A.....	pag. 14
Models 1A - Special applications.....	pag. 15

02 Double Scissor Lift Tables

Models 2E / 2A.....	pag. 16
---------------------	---------

03 Loading Lift Tables

Models 1S / 1T.....	pag. 17
---------------------	---------

04 Tandem Scissor Lift Tables

Models 5E / 5A.....	pag. 18
---------------------	---------

05 Options

.....	pag. 19
-------	---------

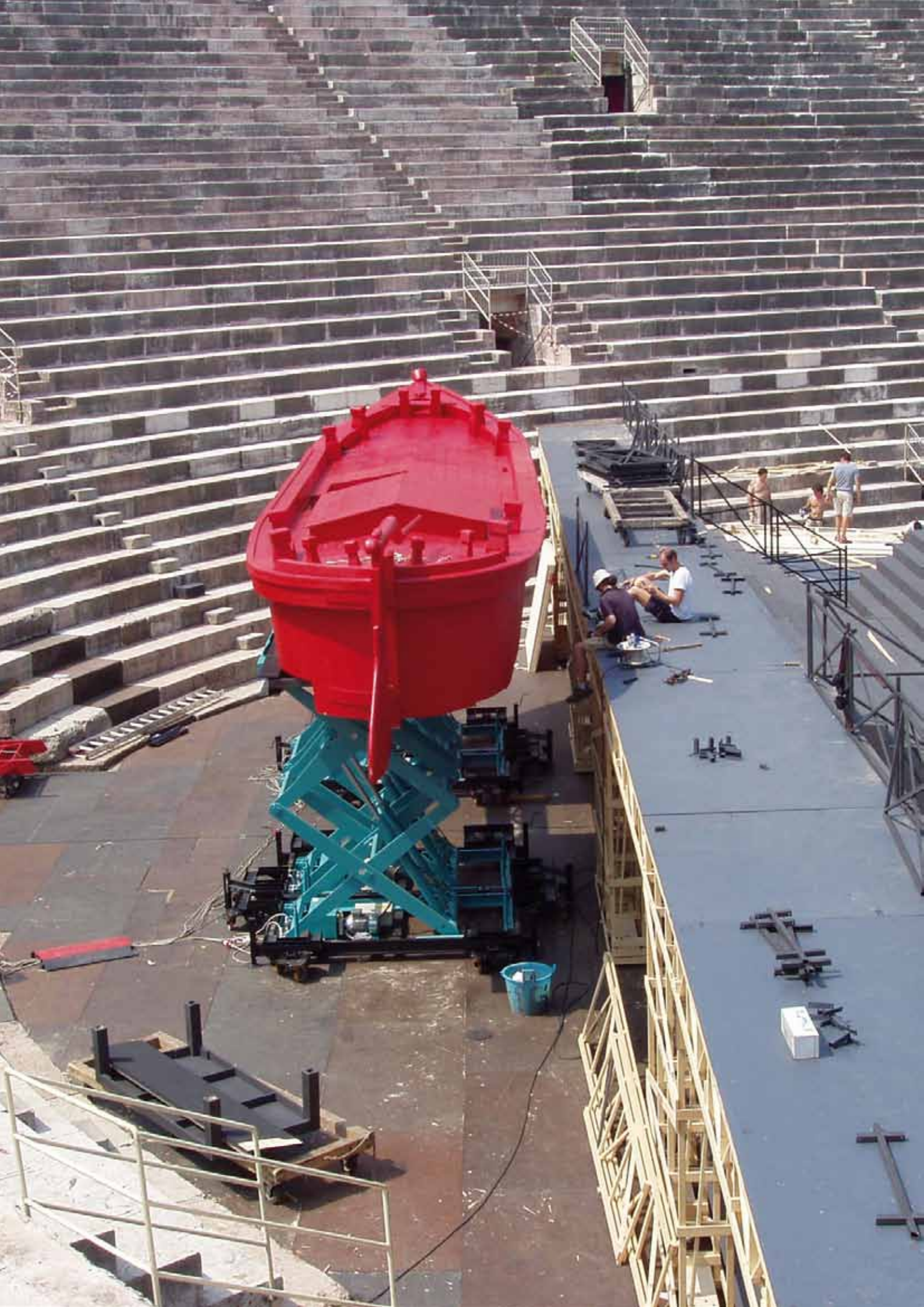

What is a lift table

Lift tables are used for lifting and lowering loads at required heights in safe conditions for the operator. Main components are the top platform, the lower frame, the scissor system activated by one or more cylinders.

Scissor lift tables have become a commonly used type of equipment in many different industries. In many cases they represent the best solution for the manual load handling, in full observance of the European standards with regards to functioning, cost saving, safety and health of operators during work.

Application fields

- Ergonomic working station
- Feeding of processing machinery (in wood, plastic, glass, steel, ceramic)
- Conveyor system, packaging system
- Loading bay
- Loading and unloading pallets for aircraft
- Connection between different stages

How to choose a Lift Table

To choose the correct lift table it is necessary to know the kind of work the table is supposed to do.

Lift table technical features

- Capacity
- Platform (A x B)
- Stroke (E)
- Collapsed height (H)
- Hydraulic power pack inside or outside
- Number of cycles per hour
- Number of shifts per day
- Lifting time
- Precision in positioning

Load features

- Weight
- Sizes
- Distribution on the platform
- Type of work

Installation

- Pit installation
- Outdoor
- Indoor
- Explosion risk
- Humidity / Warm / Cold
- Organic / chemical substances

Wide Capacity of accessories to meet the safety requirements for lift tables.

Pit

If the lift table is positioned in a pit, it is necessary to provide construction work for placement.

The drawing refers to a standard lift table without options. Please consult Bolzoni Auramo for correct pit drawing.

A = Top platform length
B = Top platform width
E = Stroke
H = Collapsed height

- 1 Angle iron pit edge protection (60x60x6)
- 2 Rainwater drainage located in the pit center 100 mm dia.
- 3 Tube for incoming hoses 100 mm dia.

Notes:

- The lower frames of the standard tables are not self-supporting. It is therefore important that the pit base is well levelled.
- It is necessary that the bottom of the pit is well drained, when necessary, providing that the rainwater drainage hole is at 80 mm lower than H.
- Output electric / hydraulic cables always from fixed side F-Y.

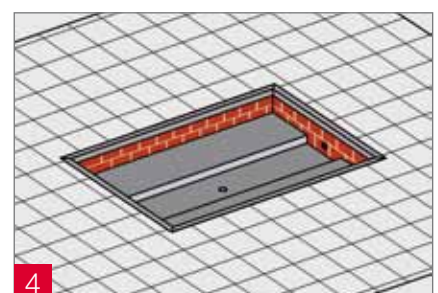
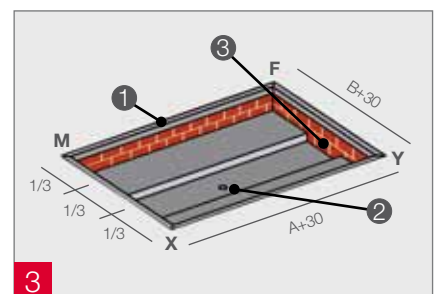
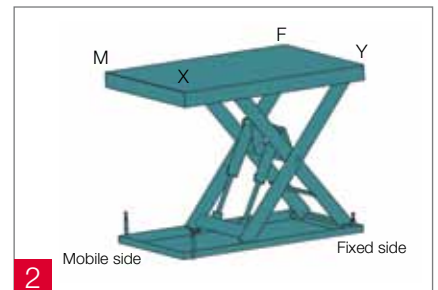
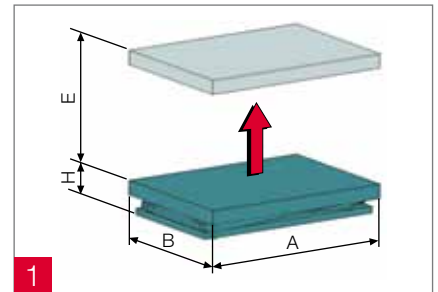



Quality and safety

The Bolzoni Auramo lift tables grant load handling, fully in compliance with the European standards concerning the safety and health of the operators.

One of our main goals is to provide the highest quality possible for products introduced on the market.

In 1991 the concepts and standards of “total quality” were introduced and in 1994 Bolzoni Auramo received the ISO 9001 certification.

Our top priority is the safety of the operator during the use of our lift tables. All lift tables comply with European standards and in particular with the Machinery Directive 2006/42/CE and Safety requirements for lift table EN 1570-1.

Lift tables are supplied with CE Declaration of Conformity or Declaration of Incorporation depending on different configurations / uses.

The installer / user is responsible for the analysis and the prevention of installation risks.

Technical features and options



All models include:

- Aluminium safety bar, stopping descent of the platform in case of contact with obstructions (fig. 1).
- Safety clearance between scissors to prevent trapping during operation (fig. 2).
- Self-lubricating bushings on pivot points.
- Single acting hydraulic cylinders equipped with rupture valve, check valve and drainage.
- Safety check valve to stop the lift table lowering in the unlikely event of a hose break (fig. 3).
- Hydraulic power pack inside the table provided with relief valve against overloading and compensated flow valve for controlled lowering speed.
- Low voltage control box (24 V) hold-to-run type (up-down-emergency-stop buttons) (fig. 4).
- Electric equipment controlled by electronic system, with transformer and thermal protection.
- Maintenance hinged bars/props (for safe maintenance operation) (fig. 5).
- Removable lifting eyes to facilitate handling and lift table installation.



The wide range of Bolzoni Auramo lift tables and options represents the optimal solution to many vertical handling requirements.

Thanks to our experience, we are able to suggest and provide customized solutions. Please contact us for further specifications and prices.

01

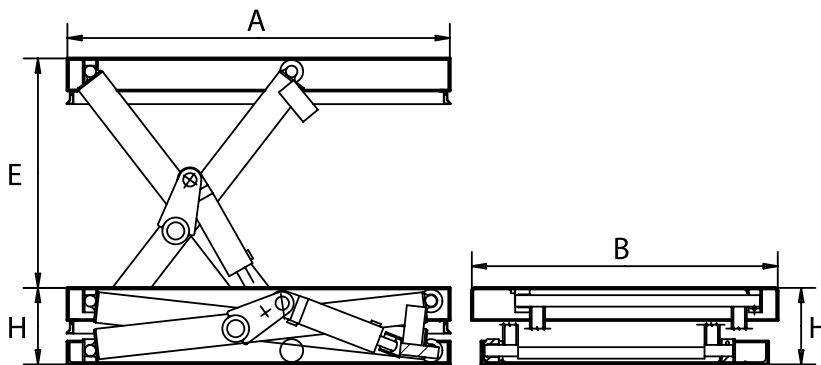

Range: 500 Kg - 2000 Kg

Designed as a "work station" to provide improved ergonomic conditions to ensure the health, safety and comfort of the operator together with improved productivity.

- Load applied: Evenly distributed.
- Top platform: Smooth surface.
- Max. 20 cycles per hour, one shift a day.
- Single acting hydraulic cylinders with drainage,
- Upper and lower position by mechanical stops.

Type Ergo-Lift 1E for evenly distributed loads

Model	Capacity	Stroke	Platform	Collapsed Height	Motor	Cylinder	
		E mm	A x B mm	H mm			
A1.05.E000	500	590	1000 x 800	200	0,55	1	60
A1.05.E010	500	800	1250 x 800	200	0,55	1	60
A1.05.E020	500	800	1250 x 1000	200	0,55	1	60
A1.05.E030	500	1000	1500 x 800	220	0,55	1	60
A1.05.E040	500	1000	1500 x 1000	220	0,55	1	60
A1.05.E050	500	1200	1800 x 800	240	0,75	1	60
A1.05.E060	500	1200	1800 x 1000	240	0,75	1	60
A1.10.E000	1000	590	1000 x 800	200	0,55	2	60
A1.10.E010	1000	800	1250 x 800	200	0,55	2	60
A1.10.E020	1000	800	1250 x 1000	200	0,55	2	60
A1.10.E030	1000	1000	1500 x 800	220	0,55	2	60
A1.10.E040	1000	1000	1500 x 1000	220	0,55	2	60
A1.10.E050	1000	1200	1800 x 800	240	0,75	2	60
A1.10.E060	1000	1200	1800 x 1000	240	0,75	2	60
A1.10.E070	1000	1600	2250 x 800	280	1,10	2	70
A1.10.E080	1000	1600	2250 x 1000	280	1,10	2	70
A1.15.E010	1500	800	1350 x 800	250	0,75	1	90
A1.15.E020	1500	800	1350 x 1000	250	0,75	1	90
A1.15.E030	1500	950	1500 x 800	260	0,75	1	90
A1.15.E040	1500	950	1500 x 1000	260	0,75	1	90
A1.15.E050	1500	1200	1800 x 800	270	1,10	1	90
A1.15.E060	1500	1200	1800 x 1000	270	1,10	1	90
A1.20.E010	2000	800	1350 x 800	250	1,10	1	110
A1.20.E020	2000	800	1350 x 1000	250	1,10	1	110
A1.20.E030	2000	950	1500 x 800	260	1,10	1	110
A1.20.E040	2000	950	1500 x 1000	260	1,10	1	110
A1.20.E050	2000	1200	1800 x 800	270	1,10	1	110
A1.20.E060	2000	1200	1800 x 1000	270	1,10	1	110



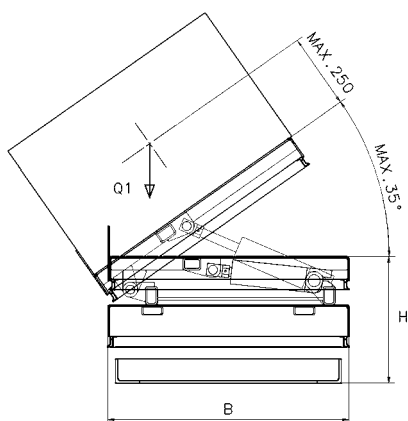

- Load applied: evenly distributed.
- Safety load retainer.
- 35° tilt (one way) by double acting cylinder.
- Aluminium safety bar, stopping descent of the platform in case of contact with obstructions.
- Low voltage (24V) control box with 5 buttons for an independent operation of the platform tilting (up - down-emergency stop – up - down tilting)

Range: 300 Kg - 1500 Kg

The Ergo-Lift table with tilting platform, allowing 35° tilt, in one direction, is useful during operation where small parts need to be picked out from container raised by the platform and can also find extensive use on assembly lines (car industry and components in general).

For special dimensions and/or pit installation contact Bolzoni Auramo.

01

Ergo-Lift 1E-T with tilting platform

Model	Capacity	Stroke	Platform	Collapsed Height	Motor	Cylinder	Lifting Time
	Q1 kg	E mm	A x B mm	H mm	Kw	n. diam.	
A1.05.E010T	300	1250 x 800	800	360	0,55	1 60	13
A1.05.E020T	300	1250 x 1000	800	360	0,55	1 60	13
A1.05.E030T	300	1500 x 800	1000	380	0,55	1 60	20
A1.05.E040T	300	1500 x 1000	1000	380	0,55	1 60	20
A1.05.E050T	300	1800 x 800	1200	400	0,75	1 60	22
A1.05.E060T	300	1800 x 1000	1200	400	0,75	1 60	22
A1.10.E010T	800	1250 x 800	800	360	0,55	2 60	26
A1.10.E020T	800	1250 x 1000	800	360	0,55	2 60	26
A1.10.E030T	800	1500 x 800	1000	380	0,55	2 60	40
A1.10.E040T	800	1500 x 1000	1000	380	0,55	2 60	40
A1.10.E050T	800	1800 x 800	1200	400	0,75	2 60	44
A1.10.E060T	800	1800 x 1000	1200	400	0,75	2 60	44
A1.10.E070T	800	2250 x 800	1600	440	1,1	2 90	37
A1.10.E080T	800	2250 x 1000	1600	440	1,1	2 90	37
A1.15.E010T	1300	1350 x 800	800	410	0,75	1 90	32
A1.15.E020T	1300	1350 x 1000	800	410	0,75	1 90	32
A1.15.E030T	1300	1500 x 800	950	420	0,75	1 90	36
A1.15.E040T	1300	1500 x 1000	950	420	0,75	1 90	36
A1.15.E050T	1300	1800 x 800	1200	430	1,1	1 90	24
A1.15.E060T	1300	1800 x 1000	1200	430	1,1	1 90	24
A1.20.E010T	1500	1350 x 800	800	410	1,1*	1 110	24
A1.20.E020T	1500	1350 x 1000	800	410	1,1*	1 110	24
A1.20.E030T	1500	1500 x 800	950	420	1,1	1 110	27
A1.20.E040T	1500	1500 x 1000	950	420	1,1	1 110	27
A1.20.E050T	1500	1800 x 800	1200	430	1,1	1 110	37
A1.20.E060T	1500	1800 x 1000	1200	430	1,1	1 110	37

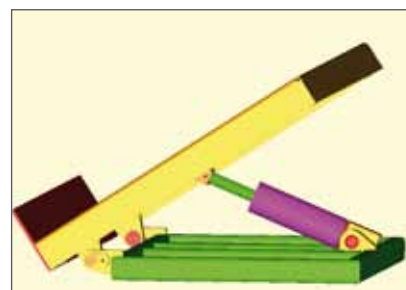

*Hydraulic power pack outside

01

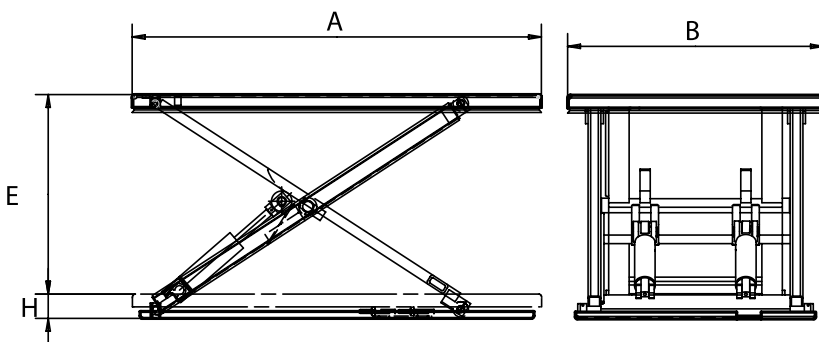

Range: 500 Kg - 2000 Kg

Low profile lift tables, due to their low closed height, do not require a floor pit, offering flexibility of location and keeping installation costs to a minimum.

Three versions are available:

- C = closed top platform
- U = U-shaped platform, particularly useful when loading a pallet safely onto the table using a hand pallet truck or pedestrian truck without the need for an access ramp.
- E = E-shaped platform, offering superior pallet support, over the conventional "U-shape" platform.

- Load applied: evenly distributed.
- Max. 20 cycles per hour, one shift a day.
- Upper limit switch.
- Remote hydraulic power pack with push button control box fixed on a stand for easier operation.

Type A8.C closed top platform for evenly distributed loads

Model	Capacity	Stroke	Platform	Collapsed Height	Motor	Cylinder
	kg	E mm	A x B mm	H mm	Kw	n. diam.
A8 05 C010	500	780	1400 x 800	82	0,75	1 60
A8 05 C020	500	780	1400 x 1000	82	0,75	1 60
A8 05 C030	500	780	1600 x 800	82	0,75	1 60
A8 05 C040	500	780	1600 x 1000	82	0,75	1 60
A8 10 C010	1000	780	1400 x 800	82	0,75	2 60
A8 10 C020	1000	780	1400 x 1000	82	0,75	2 60
A8 10 C030	1000	780	1600 x 800	82	0,75	2 60
A8 10 C040	1000	780	1600 x 1000	82	0,75	2 60
A8 15 C010	1500	750	1550 x 800	92	1,10	2 70
A8 15 C020	1500	750	1550 x 1000	92	1,10	2 70
A8 15 C030	1500	750	1700 x 800	92	1,10	2 70
A8 15 C040	1500	750	1700 x 1000	92	1,10	2 70
A8 20 C010	2000	750	1600 x 1000	95	1,10	2 70
A8 20 C020	2000	750	1600 x 1200	95	1,10	2 70



Mobility kit

Simple to install, the kit (1) allows the lift table to be moved, easily and safely, without the load, and can therefore serve multiple work stations.

Lift tables with U-shaped platform can be moved, without load, with a simple mobility plate (2) by a handpallet truck.



Type Ergo-Lift A8.U – U shaped top platform for evenly distributed load

Model	Capacity	Stroke	Platform	Collapsed Height	Motor	Cylinder	
						n.	diam.
	kg	E mm	A x B mm	H mm	Kw		
A8.10.U010	1000	780	1420 x 1140	80	0,75	2	60
A8.10.U110 ①	1000	780	1420 x 1140	80	0,75	2	60
A8.10.U120	1000	780	1420 x 1290	80	0,75	2	60
A8.15.U010	1500	750	1550 x 1160	92	1,10	2	70

01

Type Ergo-Lift A8.E – E shaped top platform for evenly distributed load

Model	Capacity	Stroke	Platform	Collapsed Height	Motor	Cylinder	
						n.	diam.
	kg	E mm	A x B mm	H mm	Kw		
A8.10.E010	1000	780	1420 x 1140	80	0,75	2	60
A8.10.E110 ①	1000	780	1420 x 1140	80	0,75	2	60
A8.10.E120	1000	780	1420 x 1290	80	0,75	2	60
A8.15.E010	1500	750	1550 x 1160	92	1,10	2	70



Notes:

- ① Model for pallet having 1000 mm width.

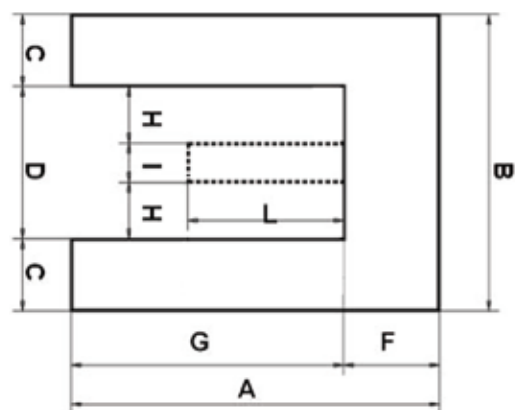

Additional dimensions for E-shaped and U-shaped top platforms

	C	D	F	G	H	I	L
A8.10.U-E010/110	277,5	585	370	1.050	217,5	150	600
A8.10.U-E120	277,5	735	370	1.050	292,5	150	600
A8.15.U-E010	287,5	585	425	1.125	217,5	150	600

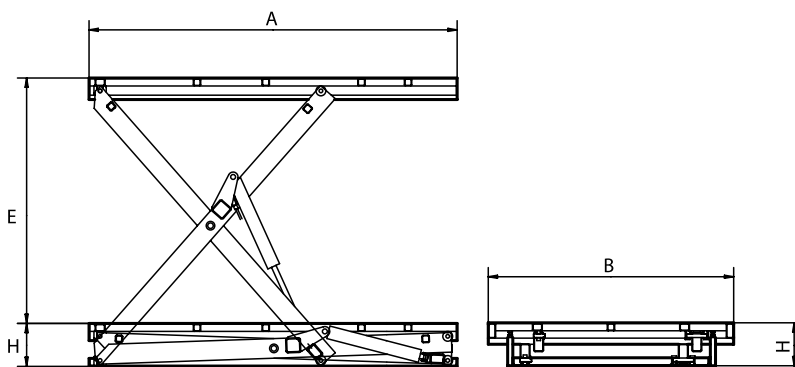

Range: 1000 Kg - 7000 Kg

Designed for heavy-duty applications solving problems throughout the industry (as part of a production process, for machine feeding or stacking etc.).

- Load applied: Partially concentrated.
- Top platform: Smooth surface.
- Max. 30 cycles per hour, one shift a day.
- Upper limit switch.



Type 1A for partially concentrated loads

Model	Capacity	Stroke	Platform	Collapsed Height	Motor	Cylinder
	kg	E mm	A x B mm	H mm	Kw	n. diam.
A1.10.A010	1000	800	1400 x 800	300	1,1	1 90
A1.10.A020	1000	800	1400 x 1000	300	1,1	1 90
A1.10.A110	1000	800	1400 x 1400	300	1,5	2 70
A1.10.A030	1000	1100	1700 x 1000	300	1,1	1 90
A1.10.A040	1000	1100	1700 x 1200	300	1,1	1 90
A1.10.A130	1000	1100	1700 x 1400	300	1,5	2 70
A1.10.A050	1000	1300	2000 x 1000	320	1,1	1 90
A1.10.A060	1000	1300	2000 x 1200	320	1,1	1 90
A1.10.A150	1000	1330	2000 x 1400	320	1,5	2 70
A1.10.A370	1000	1600	2500 x 1200	350	1,5	1 90
A1.10.A380	1000	1600	2500 x 1500	350	3,0	2 90
A1.10.A390	1000	2000	3000 x 1200	350	3,0	2 90
A1.10.A400	1000	2000	3000 x 1500	350	3,0	2 90
A1.10.A410	1000	2000	3000 x 2000	350	3,0	2 90
A1.20.A010	2000	800	1400 x 800	300	1,5	1 110
A1.20.A020	2000	800	1400 x 1000	300	1,5	1 110
A1.20.A110	2000	800	1400 x 1400	300	1,5	2 90
A1.20.A030	2000	1100	1700 x 1000	300	1,5	1 110
A1.20.A040	2000	1100	1700 x 1200	300	1,5	1 110
A1.20.A130	2000	1100	1700 x 1400	300	3,0	2 90
A1.20.A050	2000	1300	2000 x 1000	320	1,5	1 110
A1.20.A060	2000	1300	2000 x 1200	320	1,5	1 110
A1.20.A150	2000	1300	2000 x 1400	320	3,0	2 90
A1.20.A370	2000	1600	2500 x 1200	350	3,0	2 90
A1.20.A380	2000	1600	2500 x 1500	350	3,0	2 90
A1.20.A390	2000	2000	3000 x 1200	350	3,0	2 90
A1.20.A400	2000	2000	3000 x 1500	350	3,0	2 90
A1.20.A410	2000	2000	3000 x 2000	350	3,0	2 90
A1.20.A420	2000	2000	3500 x 1500	350	3,0	2 90
A1.20.A430	2000	2000	3500 x 2000	350	3,0	2 90

Model	Capacity	Stroke	Platform	Collapsed Height	Motor	Cylinder
	kg	E mm	A x B mm	H mm	Kw	n. diam.
A1.30.A010	3000	850	1500 x 1000	350	2,2	2 90
A1.30.A020	3000	850	1500 x 1200	350	2,2	2 90
A1.30.A030	3000	1200	2000 x 1000	350	3,0	2 90
A1.30.A040	3000	1200	2000 x 1200	350	3,0	2 90
A1.30.A330	3000	1600	2500 x 1200	380	3,0	2 90
A1.30.A340	3000	1600	2500 x 1500	380	3,0	2 90
A1.30.A350	3000	2000	3000 x 1500	380	4,0	2 110
A1.30.A360	3000	2000	3000 x 2000	380	4,0	2 110
A1.30.A370	3000	2000	3500 x 1500	400	4,0	2 110
A1.30.A380	3000	2000	3500 x 2000	400	4,0	2 110
A1.50.A210	5000	1600	2500 x 1500	450	4,0	2 110
A1.50.A220	5000	1600	2500 x 2000	450	4,0	2 110
A1.50.A250	5000	1800	3000 x 1500	500	4,0	2 110
A1.50.A260	5000	1800	3000 x 2000	500	4,0	2 110
A1.50.A270	5000	1800	3500 x 2000	500	4,0	2 110
A1.50.A280	5000	1800	3500 x 2400	500	4,0	2 110
A1.50.A290	5000	2000	3500 x 2000	550	4,0	2 110
A1.50.A300	5000	2000	3500 x 2400	550	4,0	2 110
A1.50.A310	5000	2000	4000 x 2400	550	4,0	2 110
A1.70.A110	7000	1500	2500 x 1500	550	4,0	2 120
A1.70.A120	7000	1500	2500 x 2000	550	4,0	2 120
A1.70.A150	7000	1800	3000 x 1500	600	4,0	2 120
A1.70.A160	7000	1800	3000 x 2000	600	4,0	2 120
A1.70.A170	7000	1800	3500 x 2000	600	4,0	2 120
A1.70.A180	7000	2000	3500 x 2000	600	4,0	2 120
A1.70.A190	7000	2000	3500 x 2400	600	4,0	2 120
A1.70.A200	7000	2000	4000 x 2400	600	4,0	2 120

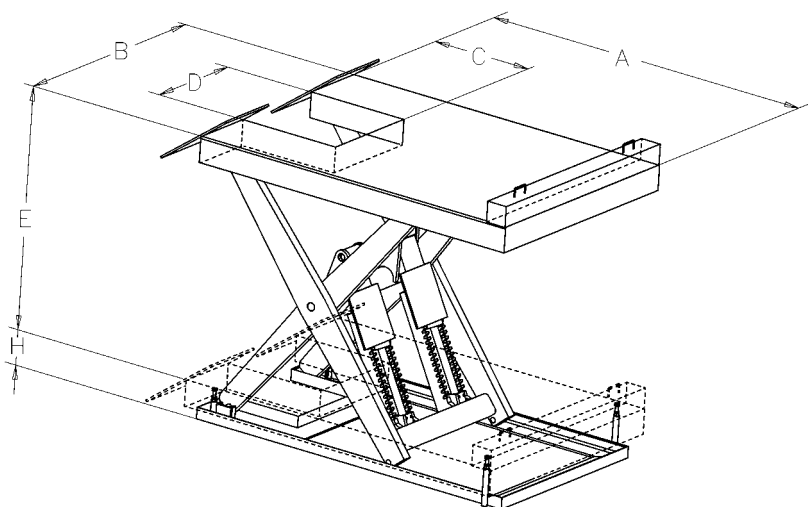

Range: 7000 Kg

During maintenance of forklift trucks, the access is complex and often physically painful for the operators.

This lift table model is specially designed to optimize the process of maintenance of forklifts and to provide optimum ergonomic workstation to improve the working conditions of the operator.

Therefore it represents an investment oriented to efficiency and productivity for maintenance and assembly of forklift trucks.

- "U" – shaped platform especially designed for forklift maintenance.
- The variable height provides the operator with an ergonomic height and freedom of movement for the maintenance of the forklift.
- The lock system is rackwork type. Unlock operations through two pneumatic cylinders.
- Flaps on the front side and safety wheels rear stop system.
- Lift tables manufactured in accordance with European Standards EN1493.



Rack system

Models 1A-LS for Forklift Truck Maintenance

Model	Capacity	Platform	Stroke	Collapsed Height	Motor	Cylinder		Lifting time	'U' shape	
	Q kg	A x B mm	E mm	H mm	Kw	n.	diam. mm	sec.	largh. mm	lungh./C mm
A1.70.A010.001W	7000	2500 x 1500	1500	450	4,0	2	120	45	650	650
A1.70.A010.002W	7000	2700 x 1500	1500	450	4,0	2	120	45	650	850

Models 1A for heavy-duty applications

An "Increased Duty Cycle Kit" is available for lift tables type 1A with capacity 1 and 2 tons, and platform length up to 2000 mm, consisting of:

- Central pivot point to feature bearings
- Upper and lower rollers to feature bearings.
- Roller sliding guides in Hardox.
- Hydraulic system to feature a constant running motor.

This system allows to increase the performances of the lift table till 70-80 cycles per hour on 3 shifts/day, representing the right solution to particularly heavy duty applications required in production processes.

Range: 1000 Kg - 2000 Kg



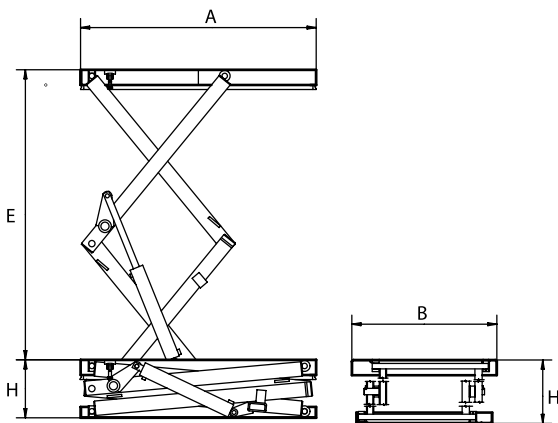

Range: 500 Kg - 3000 Kg

Used to achieve greater stroke without increasing the platform size, the double scissor lift tables model 2E and 2A are often used to connect one level to another.

- Load applied: 2E models evenly distributed – 2A models partially concentrated.
- Top platform with smooth surface (safety tread surface specially recommended in case of personnel transit).
- Max. 15 cycles per hour, one shift a day for type 2E, 10 for type 2A.



Type Ergo-Lift 2E for evenly distributed loads

Model	Capacity	Stroke	Platform	Collapsed Height	Motor	Cylinder
	kg	E mm	A x B mm	H mm	Kw	n. diam.
A2.05.E010	500	1600	1300 x 800	320	0,55	1 60
A2.05.E020	500	1600	1300 x 1000	320	0,55	1 60
A2.05.E025	500	2000	1500 x 800	350	0,55	1 60
A2.05.E026	500	2000	1500 x 1000	350	0,55	1 60
A2.05.E030	500	2000	1700 x 800	350	0,55	1 60
A2.05.E040	500	2000	1700 x 1000	350	0,55	1 60
A2.10.E010	1000	1600	1300 x 800	360	0,75	2 60
A2.10.E020	1000	1600	1300 x 1000	360	0,75	2 60
A2.10.E030	1000	2000	1700 x 800	380	1,10	2 60
A2.10.E040	1000	2000	1700 x 1000	380	1,10	2 60

Type 2A for partially concentrated loads

Model	Capacity	Stroke	Platform	Collapsed Height	Motor	Cylinder
	kg	E mm	A x B mm	H mm	Kw	n. diam.
A2.10.A050	1000	2500	2000 x 1000	450	1,1	2 60
A2.10.A060	1000	2500	2000 x 1200	450	1,1	2 60
A2.10.A280	1000	2900	2500 x 1000	550	3,0	2 70
A2.10.A290	1000	2900	2500 x 1200	550	3,0	2 70
A2.20.A010	2000	1600	1400 x 1000	450	1,1	1 70
A2.20.A020	2000	1600	1400 x 1200	450	1,1	1 70
A2.20.A030	2000	2000	1700 x 1000	500	1,1	2 70
A2.20.A040	2000	2000	1700 x 1200	500	1,1	2 70
A2.20.A050	2000	2400	2000 x 1000	500	1,5	2 70
A2.20.A060	2000	2400	2000 x 1200	500	1,5	2 70
A2.20.A260	2000	2900	2500 x 1200	600	3,0	2 90
A2.20.A280	2000	2900	2500 x 1500	600	3,0	2 90
A2.20.A290	2000	3500	3000 x 1500	650	4,0	2 90
A2.30.A210	3000	1500	1500 x 1200	600	3,0	1 120
A2.30.A220	3000	1800	1800 x 1200	600	3,0	2 90
A2.30.A230	3000	2300	2000 x 1200	600	4,0	2 110
A2.30.A240	3000	2900	2500 x 1200	600	4,0	2 110
A2.30.A250	3000	3500	3000 x 1500	650	4,0	2 110
A2.30.A260	3000	3500	3000 x 2000	650	4,0	2 110

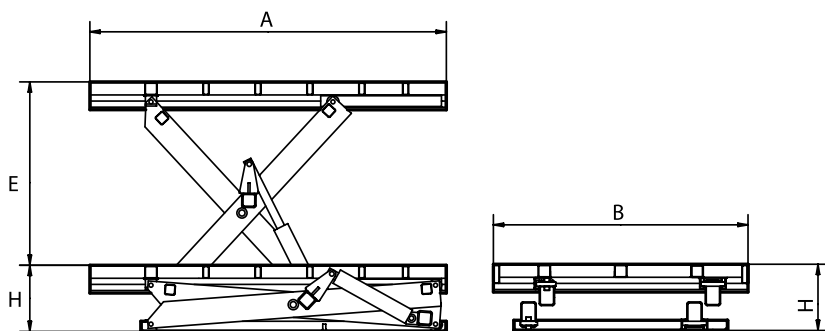

Range: 1000 Kg - 10000 Kg

Ideal to load and unload vehicles by pedestrian or fork lift trucks without a loading deck.

Lift tables range designed to work with highest safety also with off-centered and moving loads.

- Safety tread top platform surface.
- Max. 20 cycles per hour, one shift a day.
- Upper limit switch.

A wide range of options – such as manual bridge plate, safety handrails, goal posts – is available for specific requirements and to comply with safety standards.

03

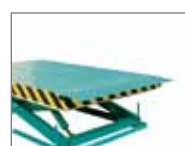

Roll-off stop



Manual bridge plate



Safety handrail

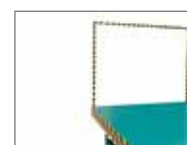

Goal posts



1S single scissor lift table for loading by pedestrian trucks

Model	Capacity	Stroke	Platform	Collapsed Height	Motor	Cylinder
	kg	E mm	A x B mm	H mm	Kw	n. diam.
A1 10 S010	1000	1600	2500 x 1200	350	1,5	1 90
A1 10 S120	1000	2000	3000 x 1500	350	3,0	2 90
A1 10 S130	1000	2000	3000 x 2000	350	3,0	2 90
A1 20 S110	2000	1600	2500 x 1500	350	3,0	2 90
A1 20 S120	2000	1600	2500 x 2000	350	3,0	2 90
A1 20 S130	2000	2000	3000 x 1500	350	3,0	2 90
A1 20 S140	2000	2000	3000 x 2000	350	3,0	2 90
A1 20 S150	2000	2000	3500 x 2000	350	3,0	2 90
A1 30 S110	3000	1600	2500 x 1500	380	3,0	2 90
A1 30 S120	3000	1600	2500 x 2000	380	3,0	2 90
A1 30 S130	3000	2000	3000 x 1500	380	4,0	2 110
A1 30 S140	3000	2000	3000 x 2000	380	4,0	2 110
A1 30 S150	3000	2000	3500 x 2000	400	4,0	2 110



1T single scissor lift table for loading by forklift trucks

Model	Capacity	Stroke	Platform	Collapsed Height	Motor	Cylinder
	kg	E mm	A x B mm	H mm	Kw	n. diam.
A1 40 T000	4000	1600	2500 x 2000	500	4,0	2 110
A1 40 T010	4000	1600	3000 x 2000	500	4,0	2 110
A1 40 T020	4000	1800	3000 x 2000	550	4,0	2 110
A1 40 T030	4000	1800	3000 x 2400	550	4,0	2 110
A1 40 T040	4000	1800	3500 x 2400	550	4,0	2 110
A1 40 T050	4000	2000	3500 x 2000	550	4,0	2 110
A1 40 T060	4000	2000	3500 x 2400	550	4,0	2 110
A1 40 T070	4000	2000	4000 x 2400	550	4,0	2 110
A1 60 T000	6000	1500	2500 x 2000	550	4,0	2 120
A1 60 T010	6000	1800	3000 x 2000	600	4,0	2 120
A1 60 T020	6000	1800	3000 x 2400	600	4,0	2 120
A1 60 T030	6000	1800	3500 x 2400	600	4,0	2 120
A1 60 T050	6000	2000	3500 x 2000	600	4,0	2 120
A1 60 T060	6000	2000	3500 x 2400	600	4,0	2 120
A1 60 T070	6000	2000	4000 x 2400	600	4,0	2 120
A1 80 T000	8000	1500	2500 x 2000	600	4,0	2 130
A1 80 T010	8000	1800	3000 x 2000	650	4,0	2 130
A1 80 T020	8000	1800	3000 x 2400	650	4,0	2 130
A1 80 T030	8000	1800	3500 x 2400	650	4,0	2 130
A1 80 T050	8000	2000	3500 x 2000	650	4,0	2 130
A1 80 T060	8000	2000	3500 x 2400	650	4,0	2 130
A1 80 T070	8000	2000	4000 x 2400	650	4,0	2 130
A1 A0 T000	10000	1500	2500 x 2000	650	5,5	2 140
A1 A0 T050	10000	2000	3500 x 2000	700	5,5	2 140
A1 A0 T060	10000	2000	3500 x 2400	700	5,5	2 140
A1 A0 T070	10000	2000	4000 x 2400	700	5,5	2 140



Tandem Scissor Lift Tables

Models 5E / 5A

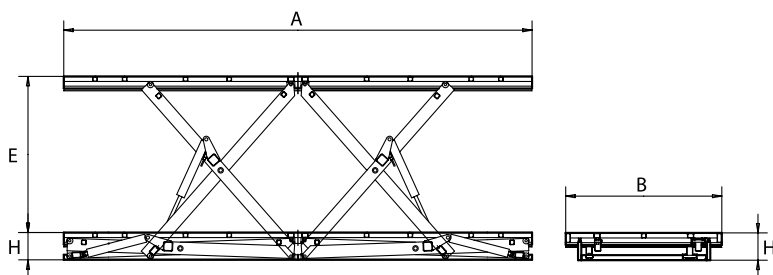

Range: 1000 Kg - 6000 Kg

Designed to handle extra long and heavy loads whilst keeping the closed dimension to a minimum.

04

- Load applied: type 5E evenly distributed – type 5A partially concentrated.
- Top platform: smooth surface.
- Max. 20 cycles per hour, one shift a day.
- Upper limit switch.



Type Ergo-Lift 5E for evenly distributed load

Model	Capacity	Stroke	Platform	Collapsed Height	Motor	Cylinder
	kg	E mm	A x B mm	H mm	Kw	n. diam.
A5 05 E010	1000	800	2500 x 800	200	0,75	2 60
A5 05 E020	1000	800	2500 x 1000	200	0,75	2 60
A5 05 E030	1000	1000	3000 x 800	220	0,75	2 60
A5 05 E040	1000	1000	3000 x 1000	220	0,75	2 60
A5 05 E050	1000	1200	4000 x 800	240	0,75	2 60
A5 05 E060	1000	1200	4000 x 1000	240	0,75	2 60
A5 10 E010	2000	800	2500 x 800	200	1,10	4 60
A5 10 E020	2000	800	2500 x 1000	200	1,10	4 60
A5 10 E030	2000	1000	3000 x 800	220	1,10	4 60
A5 10 E040	2000	1000	3000 x 1000	220	1,10	4 60
A5 10 E050	2000	1200	4000 x 800	240	1,10	4 60
A5 10 E060	2000	1200	4000 x 1000	240	1,10	4 60
A5 20 E110	4000	950	3200 x 800	260	1,10	2 110
A5 20 E120	4000	950	3200 x 1000	260	1,10	2 110
A5 20 E130	4000	1200	3800 x 800	270	1,50	2 110
A5 20 E140	4000	1200	3800 x 1000	270	1,50	2 110
A5 20 E130	4000	1200	3800 x 800	270	1,50	2 110
A5 20 E140	4000	1200	3800 x 1000	270	1,50	2 110

Type 5A for partially concentrated loads

Model	Capacity	Stroke	Platform	Collapsed Height	Motor	Cylinder
	kg	E mm	A x B mm	H mm	Kw	n. diam.
A5 10 A020	2000	1000	3500 x 1000	300	1,5	2 90
A5 10 A040	2000	1600	5000 x 1000	350	3,0	2 90
A5 20 A020	4000	1000	3500 x 1000	300	3,0	2 110
A5 20 A040	4000	1600	5000 x 1200	350	4,0	4 90
A5 30 A020	6000	1600	5000 x 1200	380	4,0	4 90
A5 30 A040	6000	1600	5000 x 2000	380	4,0	4 90

Wide range of accessories to meet the safety requirements for lift tables.

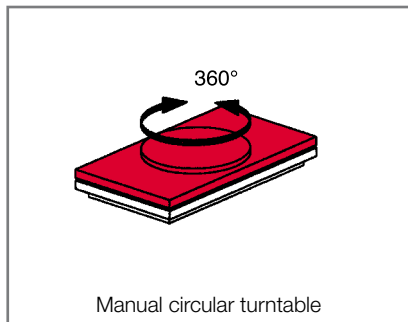

Manual circular turntable

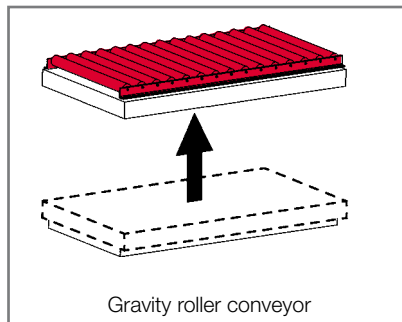

Gravity roller conveyor

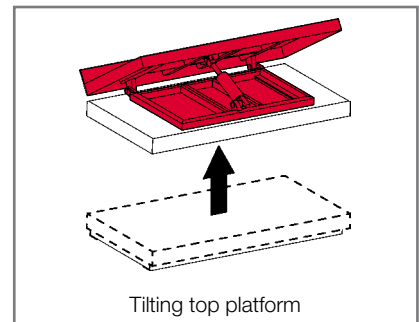

Tilting top platform

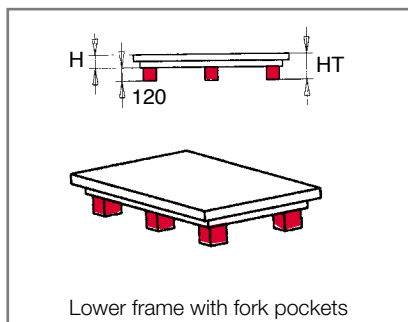

Lower frame with fork pockets

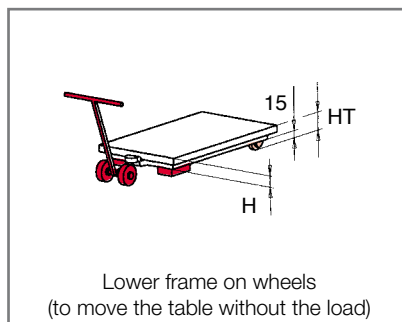

Lower frame on wheels
(to move the table without the load)

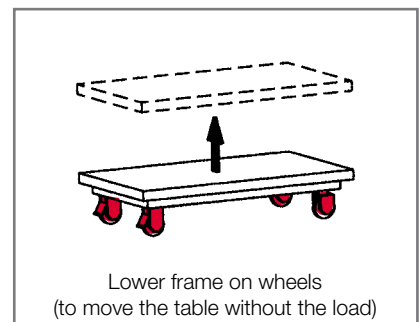

Lower frame on wheels
(to move the table without the load)

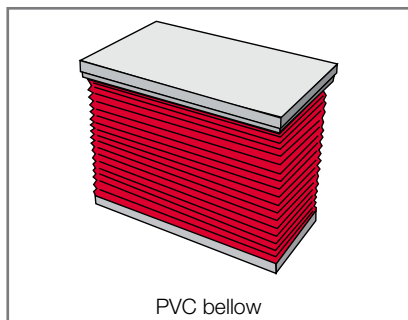

PVC bellow

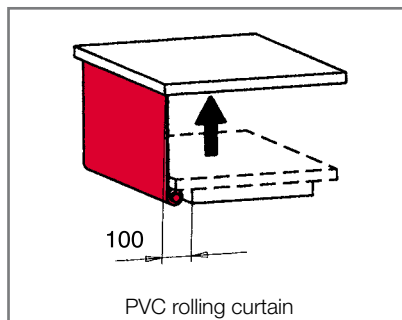

PVC rolling curtain

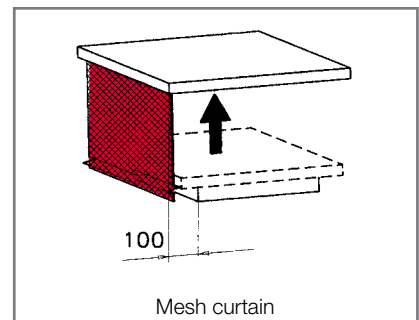

Mesh curtain

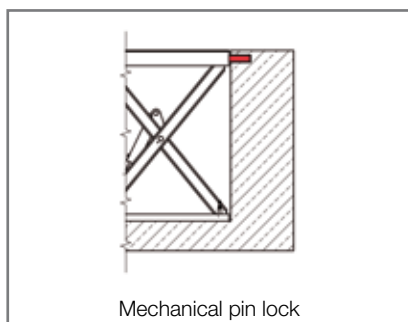

Mechanical pin lock

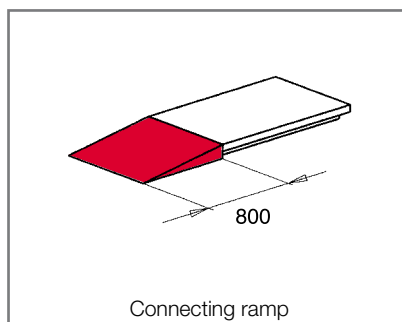

Connecting ramp

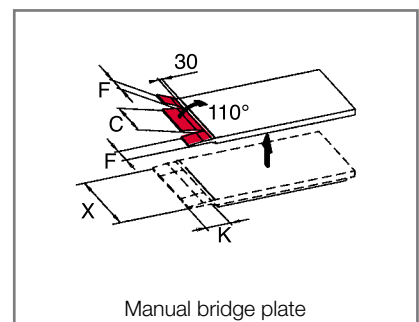

Manual bridge plate

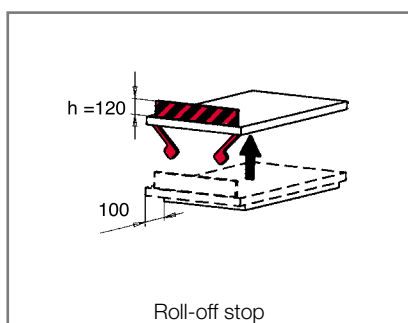

Roll-off stop

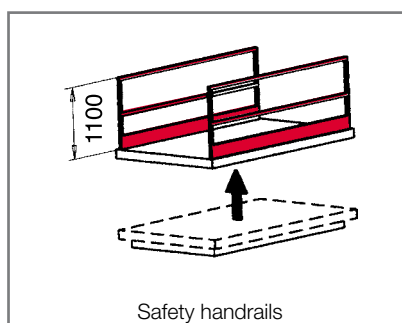

Safety handrails

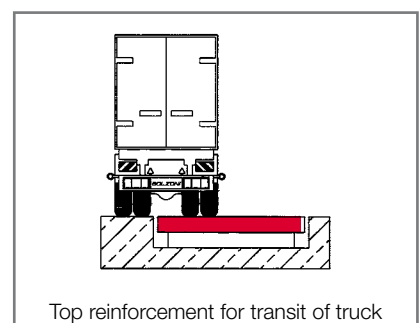

Top reinforcement for transit of truck

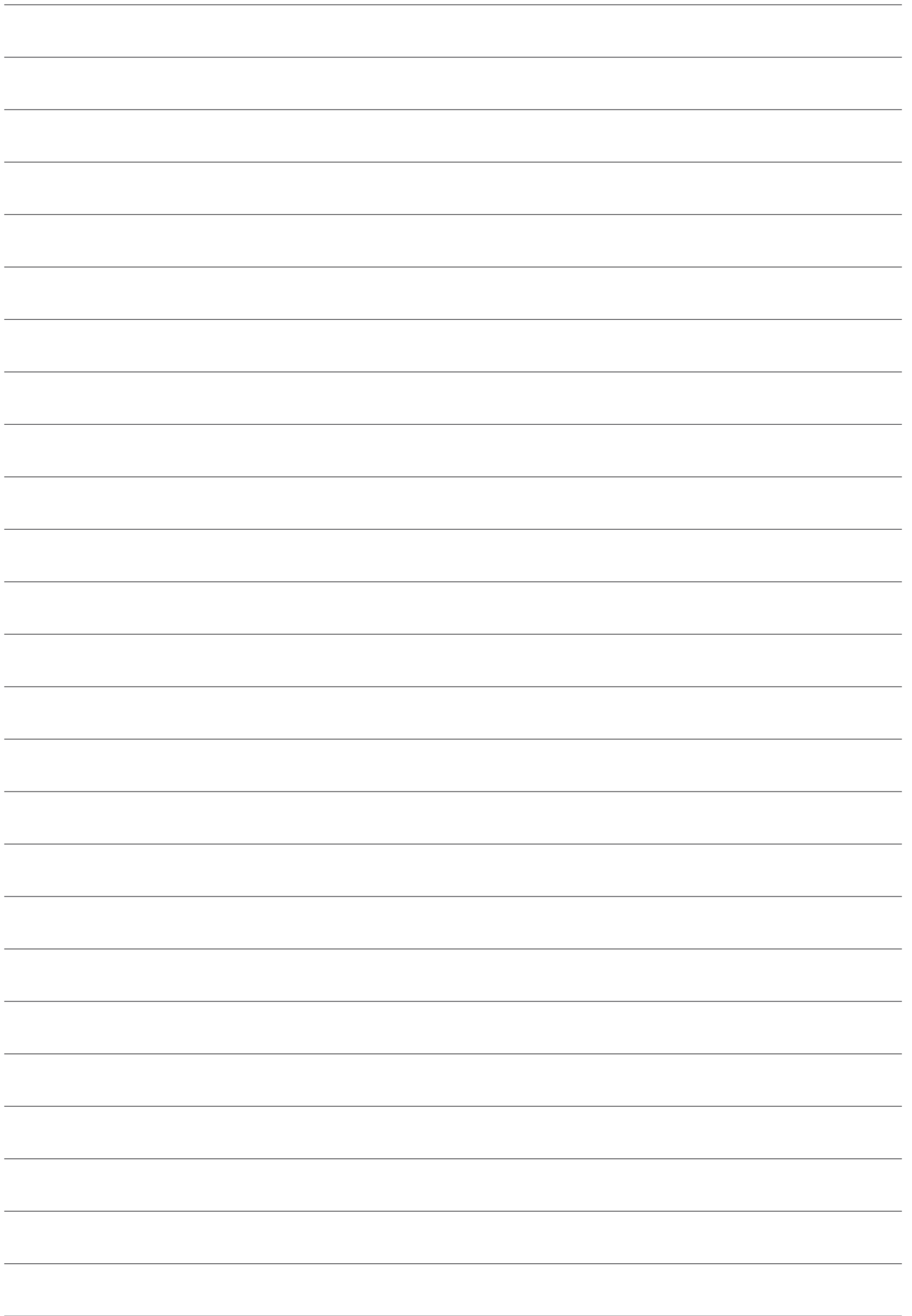

CONTACTS

BOLZONI S.p.A.

Headquarters

I-29027 Casoni di Podenzano
Piacenza - Italy
Tel: +39-0523-55-55-11
sales.it@bolzoni-auramo.com

EUROPE

AURAMO OY

P.O.Box 78 - Valimotie 22
FIN-01511 Vantaa - **Finland**
Tel: +358-9-82-931
sales.fi@bolzoni-auramo.com

BOLZONI Sarl

Rue Avogadro
Technopôle de Forbach-Sud
F-57600 Forbach - **France**
Tel: +33-3-87-84-65-40
sales.fr@bolzonigroup.com

Hans H. MEYER GmbH

Gittertor 14
D-38259 Salzgitter - **Germany**
Tel: +49-5341-803-0
info@meyer-sz.de

Mühlenstr. 74
DE-41352 Korschenbroich - **Germany**
Tel: +49-2161-999-36-0
sales.de@bolzoni-auramo.com

BOLZONI ITALIA S.r.l.

Via del Mandorlo, 28
I-59100 Prato - **Italy**
Tel: +39-0574-57-13-53
info.italia@bolzonigroup.com

BOLZONI AURAMO BV

Waterbeemd 6a
NL-5705 DN Helmond
Industrieterrein nr. 8955
The Netherlands
Tel: +31-492-50-97-77
sales.benelux@bolzoni-auramo.com

BOLZONI AURAMO

POLSKA Sp. z o.o.
Tokerska 9C
PL-20-210 Lublin - **Poland**
Tel: +48-81-44-65-491
sales.pl@bolzoni-auramo.com

BOLZONI AURAMO S.L.

c/ Segre, 8-10
P.I. Plà d' en Coll
E-08110 Montcada i Reixac
Barcelona - **Spain**
Tel: +34-938-648-633
sales.es@bolzoni-auramo.com

BOLZONI AURAMO AB

Beckasinvägen 9A
SE-803 09 Gävle - **Sweden**
Tel: +46-26-64-72-30
sales.se@bolzoni-auramo.com

BOLZONI Ltd

Unit 10, Taurus Park
Europa Boulevard - West Brook
Warrington Cheshire WA5 7ZT
United Kingdom
Tel: +44-1925-62-45-70
sales.uk@bolzoni.net

LLC "Hans H. Meyer OOO"

Krasnogo Mayka Str. 26
Moscow, 117570 - **Russia**
Tel: +7-495-374-54-34
Fax: +7-495-374-54-34
info@bolzonigroup.ru

CEMAT trading, spol. s.r.o.

Cs. armady 184
CZ-735 51 Bohumin - Pudlov
Czech Republic
Tel: +420-596-092-333
cemat@cemat.cz

KIANDRA TARGO KFT.

Csépi út 2644/9,
H-2316 Tököl - **Hungary**
Tel: +36-20-967-95-66
krajczar.istvan@kiandra.hu

Bolzoni Auramo

Lisboa Office - Portugal
Tel./ Fax: +351-212-90-2551
Mob: +351-917-884976
lsilva@bolzoni-auramo.com

Lift Systems S.r.l.

Sos. Bucuresti-Târgoviste 22N
RO-013505 Bucuresti, sector 1
Romania
Tel: +40-31-4048-039
Fax: +40-31-4048-039
office@liftsystems.ro

MCGOWAN ENGINEERING Ltd

Lightburn Road - Cambuslang
Glasgow G72 7XS - **Scotland (U.K.)**
Tel: +44-141-641-3648 /2359
info@mcgowaneng.co.uk

CEMAT s.r.o.

Sucianska cesta 31
036 08 Martin - **Slovak Republic**
Tel: +421-43-430-25-63
cemat@cemat.sk
www.cemat.sk

BAMY Hidrolik Ekipmanlar ve

Ticaret Ltd. Sti.
Zahitbey Sok No:12 D:1
TR-34724 Kalamis, Kadikoy
Istanbul - **Turkey**
Tel: +90-216-34-53-383
bilgi@ba-my.com

MAX URECH

Lager- und Fördertechnik
Parallelstrasse 4
5606 Dintikon - **Switzerland**
Tel: +41-56-616-7010
Fax: +41-56-616-7020
info@max-urech.ch

Fourtec Fördertechnik GmbH

Töschling 123
9210 Pörtschach - **Austria**
Tel: +43-4272-44796-0
Fax: +43-4272-44796-20
office@fourtec.at

AMERICA

BOLZONI AURAMO CANADA Ltd

90C Brunswick Blvd
Dollard-des-Ormeaux,
Quebec H9B 2C5 - **Canada**
Tel: +1-800-685-78 71 (Canada only)
Tel: +1-514-685-78 71
sales.ca@bolzoni-auramo.com

BOLZONI AURAMO Inc.

17635 Hoffman Way
Homewood, Illinois 60430
USA
Tel: +1-800-358 54 38 (USA only)
Tel: +1-708-957 88 09
sales.us@bolzoni-auramo.com

LIFT PRODUCTS Inc.

W226 N900 Eastmound Dr A
Waukesha, Wisconsin 53186 - **USA**
Toll Free: 877-543-8776 (USA only)
Tel: +1-262-521-5720
bill@liftproducts.com

PLP Autoelevadores

Calle 9 entre 8 y 10 RPI T.1
1629 Parque Industrial de Pilar
Buenos Aires - **Argentina**
Tel: +54-2322-530000 int. 128
info@plpautoelevadores.com.ar

ANVAL S.A.

Avda.La Dehesa 1201 - Of. 810
Edificio Oriente - CP 769 0277
Lo Barnechea - Santiago - **Chile**
Tel: +56-2-951-6907
clara.leon@anval.cl

ASIA

Bolzoni-Huaxin (HEBEI)

Forks Manufacturing Co., Ltd.
Industrial Base of Long Hua Town
Jing County Hebei Province
P.R.China
Tel: +86-0318-5835-388
sales@bolzoni-auramo.com.cn

Bolzoni-Auramo (WUXI)

Forklift Truck Attachment Co., Ltd.
Antai 2nd Road NO. 2566,
Xishan District, Wuxi, Jiangsu, 214106
P.R.China
Tel: +86-510-8853-5365
sales@bolzoni-auramo.com.cn

PT. A&T Engineering

Jl. Raden Inten No. 66F
Jakarta - Timur 13440 - **Indonesia**
Tel: +62-21-8661-2611
adrius@at-engineering.co.id

Saudi Power Line Trading Co. Ltd.

P.O. Box 31759,
Al-Khobar 31952
Kingdom of Saudi Arabia
Tel: +966-3-8978444
info@powerline-sa.com

RFA Industries Pte. Ltd.

No.7 & 9, Jalan Sg Kandis 27/92
Taman Alam Megah,
Section 27, 40400,
Shah Alam, Selangor - **Malaysia**
Tel: +60-03-5192-2000
enquiry@rfa-industries.com

RFA Industries Pte. Ltd

140/14 Moo 12, Tambol Rajataewa,
619864 - **Singapore**
Tel: +65-6862-3011
enquiry@rfa-industries.com

RFA Industries Pte. Ltd

140/14 Moo 12, Tambol Rajataewa,
Amphur Bangphlee, Samutprakarn,
10540 Bangkok - **Thailand**
Tel: +662-750-1331, 750-3011
enquiry@rfa-industries.com

AFRICA

BOLZONI AURAMO

SOUTH AFRICA (Pty) Ltd
9, Indiana Street, Apex Ext 3, Benoni
South Africa
Tel: +27-11-421-07-38
sales.za@bolzoni-auramo.com

OCEANIA

BOLZONI AURAMO (Pty) Ltd

Unit 2, 8-10 Avallil Road
Prestons NSW 2170 - **Australia**
Tel: 1300 265 966 (Australia only)
Tel: +612-8798-2774
sales.au@bolzoni-auramo.com

RT Equipment Limited

58, Hobill Avenue
Manukau City,
Auckland - **New Zealand**
Tel: +64-9-262-07-21
christ@rtequipment.co.nz





www.bolzonigroup.com